



Service Manual

Gas/Electric Refrigerators

MODELS

1200XX

120X-IMXX



WARNING

DO NOT install this refrigerator in below deck marine applications. Do not install this refrigerator in fixed indoor cabin or other dwelling applications. This refrigerator must use only NORCOLD designed and approved outside air intake and exhaust ventilation for correct and safe operation. Any other ventilation could cause lethal combustion exhaust fumes and or/explosive propane gas fumes to be in the living area and/or below deck.

This page intentionally left blank.

Table of Contents

INTRODUCTION	1
About this Manual	1
Model Identification	1
Information Label	1
Cooling Unit Serial Number	1
Certification and Code Requirements	1
About Installation	1
Replacement Parts	1
Technical Assistance	1
SAFETY AWARENESS	3
Safety Notice	3
Attention Statements	3
Safety Statements	3
SPECIFICATIONS	4
1200XX/120X-IMXX Models	4
TROUBLESHOOTING QUICK REFERENCE GUIDE	5
DISPLAYED FAULT CODES: S/N 832170 & LOWER	6
DISPLAYED FAULT CODES S/N 832171 & HIGHER	8
TROUBLESHOOTING FLOWCHARTS	9
Blank Display – Refrigerator does not turn on	9
"no" "LP" / "no" "FL" Fault Code	10
"dc" "LO" Fault Code	11
"sr" "FS"/"Sr" Fault Code	11
"dc" "HI" Fault Code	16
"sr" "CL"/"AC" "rE" Fault Code	16
"no" "AC" Fault Code	17
"AC" "LO" Fault Code	18
"AC" "HI" Fault Code	18
"AC" "HE" Fault Code	19
"dr" Fault Code	20
Thermistor Open	21
Backup Operating System (BOS)	21
1200XX/120X-IMXX Backup Operation, S/N 832170 and Lower	21
1200XX/120X-IMXX Backup Operation, S/N 832171 and higher	21
Power Board Resetting Procedure	22
"no" "co" Fault Code S/N 832171 and higher	22
VENTILATION	19
Roof Exhaust Venting	19
Air Intake Vent	19
Roof Exhaust Vent	19
Baffles	20
Vertical Angled Baffles	20
Double Sidewall Venting	21
Air Intake Vent	21
Sidewall Exhaust Vent	21

LP GAS SYSTEM

Pressure Requirements	24
Components	24
Testing for LP Gas Leaks	25
Gas Valve	25
Solenoid Gas Valve Connections	25
Replacing Old Style Gas Valve	25
Burner Tube	26
Burner	26
Orifice	26
Flue	27
Flue Cap	27
Flue Baffle	27
Burner Cleaning Procedure	28

ELECTRICAL REQUIREMENTS/COMPONENTS

DC Voltage Requirements and Polarity	29
Power Board DC Fuse	29
DC Power Wiring Requirements	29
AC/DC Converter as Power Source	29
Divider Heater	29
Lamp/Thermistor Assembly	29
AC Power Requirements	30
AC Heaters	30
AC Heaters Circuit Fuse	30
Power Board AC Power Cord	30
Ice Maker AC Power Cord - Earlier Models	31
Ice Maker AC Power Cord	31
12 volt DC Fans	31

COOLING UNIT

Description	32
Heat Absorption	32
Leveled Operation	32
Gradual Decrease in Cooling Efficiency	32
Cooling Performance Monitoring Control	32
Cooling Unit Monitoring Control Operation	33
First "no co" Fault Occurrence	33
Second "no co" Fault Occurrence	33
Refrigerant Leakage	33
Disposal of Cooling Unit	33
Cooling System Diagnostic Flowchart	34

Replacing the Cooling Unit

Removing the Refrigerator and Cooling Unit	36
Removing Cooling Unit	36
Installation of Replacement Cooling Unit	36
Reinstallation of Refrigerator into Enclosure	36

ELECTRONIC COMPONENTS

Power Board	40
Removal–Power Board	40

Installation–Power Board.....	40	DIAGNOSTIC MODE - UNITS S/N 832171 AND HIGHER.....	49
CONTROLS.....	41	Diagnostic Mode	49
Optical Control Display Assembly	41	Accessing the Diagnostic Mode.....	49
AUTO AC Operation	41	Changing Screens	49
Modes of Operation, S/N 832170 and Lower	42	Exiting the Diagnostic Mode	49
AUTO	42	Screens and Diagnostic Segments Information	50
AUTO LP Operation.....	42	WIRING PICTORIAL AND DIAGRAM/SN 832170 AND LOWER ..	52
Shift from AUTO LP GAS to AUTO AC	42	WIRING PICTORIAL AND DIAGRAM/SN 832171 AND HIGHER..	54
No AC Power and No Flame.....	42	ICE MAKER COMPONENTS AND SERVICE.....	56
Troubleshooting No Flame and No AC Faults	43	Specifications.....	56
AC Manual Mode	43	Wire Harness	56
No AC Power Present or Loss of AC Power	43	Water Fill Tube.....	57
AC Power Restored	43	Water Fill Line.....	57
Troubleshooting "no AC" Fault	43	12 volt DC Water Line Heater	57
LP Manual Mode.....	43	Water Valve (Without Water Dispenser).....	58
Modes of Operation, S/N 832171 and Higheri	44	Water Valve Replacement Procedure.....	58
AUTO	44	Ice Maker Troubleshooting Chart.....	59
AUTO AC Operation	44	Water Valve Service	59
AUTO LP Operation.....	44	Replacing Ice Maker	60
Shift from AUTO LP GAS to AUTO AC	44	Cycle Testing Ice Make.....	61
No AC Power and No Flame.....	44	Checking Water Valve Operation.....	61
Troubleshooting No Flame and No AC Fault	44	Water Fill Adjustment	62
AC Manual Mode	45	Checking Water Valve Solenoid Resistance.....	64
No AC Power or Loss of AC Power	45	Checking Mold Heater Resistance	63
AC Power Restored	45	Checking Voltage to Motor.....	63
Troubleshooting "no AC" Fault	45	Winterization	63
LP Manual Mode.....	45		
DIAGNOSTIC MODE - S/N 832170 AND LOWER.....	46		
Diagnostic Mode	46		
Accessing the Diagnostic Mode.....	46		
Changing Screens	46		
Exiting the Diagnostic Mode	46		
Screens and Diagnostic LEDES Information, Units with S/N 832170 and Lower	47		

About this Manual

This service manual provides maintenance, diagnostic, and repair information for **NORCOLD, INC.** model 1200XX/120X-IMXX gas absorption refrigerators. It is a reference tool designed for technicians who are knowledgeable in the theory and operation of gas/electric absorption refrigerators, liquefied petroleum (LP) gas (propane) system, and AC/DC electrical systems as installed in a variety of recreational vehicles (RV).

All information, illustrations, and specifications contained in this publication are based on the latest product information available at the time of publication. **NORCOLD®** reserves the right to make changes at any time without notice.

Model Identification

Model 1200XX/120X-IMXX are 2-way refrigerators that can operate on AC power or LP gas. The electronic controls operate on 12 Vdc.

Letter(s) appended to the model number identify factory installed accessories. For example, a 1200-IMSS is a 2-way refrigerator equipped with an ice maker and stainless steel doors.

Information Label

The information label is located in the upper right corner of the fresh food compartment just below the divider. See Figure 1, page 2. The label provides the following information:

- Serial number.
- Model number.
- LP gas (propane) pressure.
- Btu/hr.
- AC voltage and amperage.
- DC voltage and amperage.
- Design certification.
- Vent kit requirement.

Cooling Unit Serial Number

The cooling unit has a separate serial number that appears on the cooling unit bar code label. The label is affixed to the surface of the cooling unit leveling chamber. See Figure 2, page 2.

Certification and Code Requirements

NORCOLD® 1200XX/120X-IMXX gas/electric absorption refrigerators are certified under the latest edition of *ANSI Z21.19B* standards for installation in mobile homes or recreational vehicles. **NORCOLD, INC.** 1200XX/120X-IMXX gas/electric absorption refrigerators are also certified with the Canadian Standards Association, *CAN/CGA-1.4-M94*.

Electrical components are  compliant.

About Installation



Refrigerator installation must conform with the *1200XX/120X-IMXX Installation Manual* for the **NORCOLD, INC.** limited warranty to be in effect. Installation must also comply with applicable local codes and standards set by the applicable certification agency.

Replacement Parts

Use only authorized **NORCOLD®** replacement parts. Generic parts do not meet **NORCOLD®** specifications for safety, reliability, and performance. The use of unauthorized aftermarket or generic replacement parts voids the refrigerator's limited warranty coverage.

Technical Assistance

If unable to resolve technical issues using the information provided in this manual, technical support for service technicians is available through the **NORCOLD, INC.** Customer Service Center:

-  Telephone:1-800-444-7210.
-  Fax:1-937-497-3183.
-  World Wide Web:www.norcold.com.

The following information is required to process technical support requests:

- Model number.
- Serial number.
- Make, model, and year of recreational vehicle.

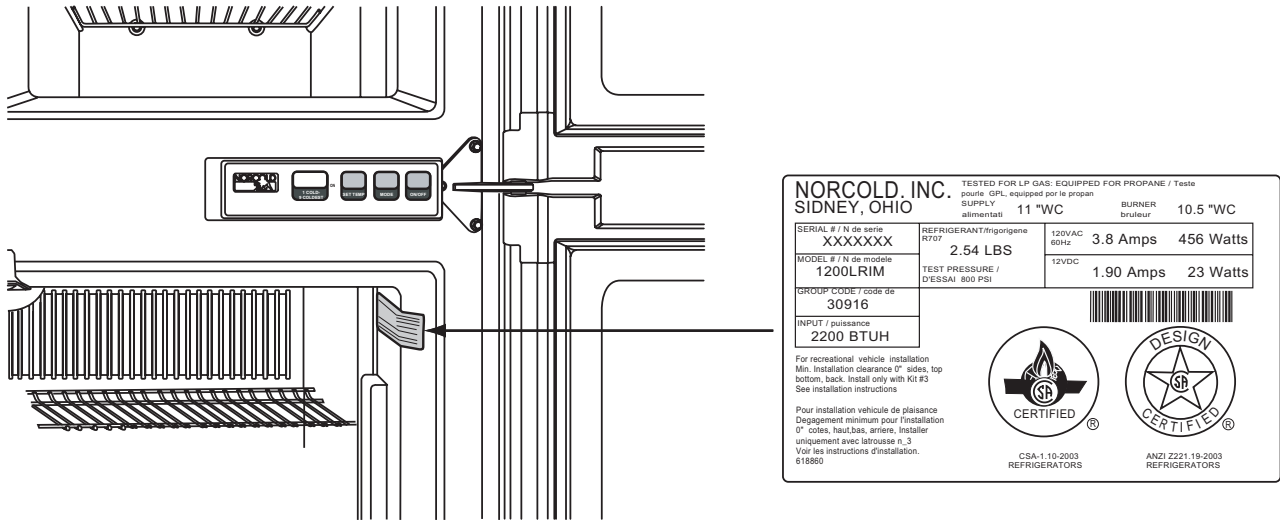

Figure 1. Refrigerator information label location

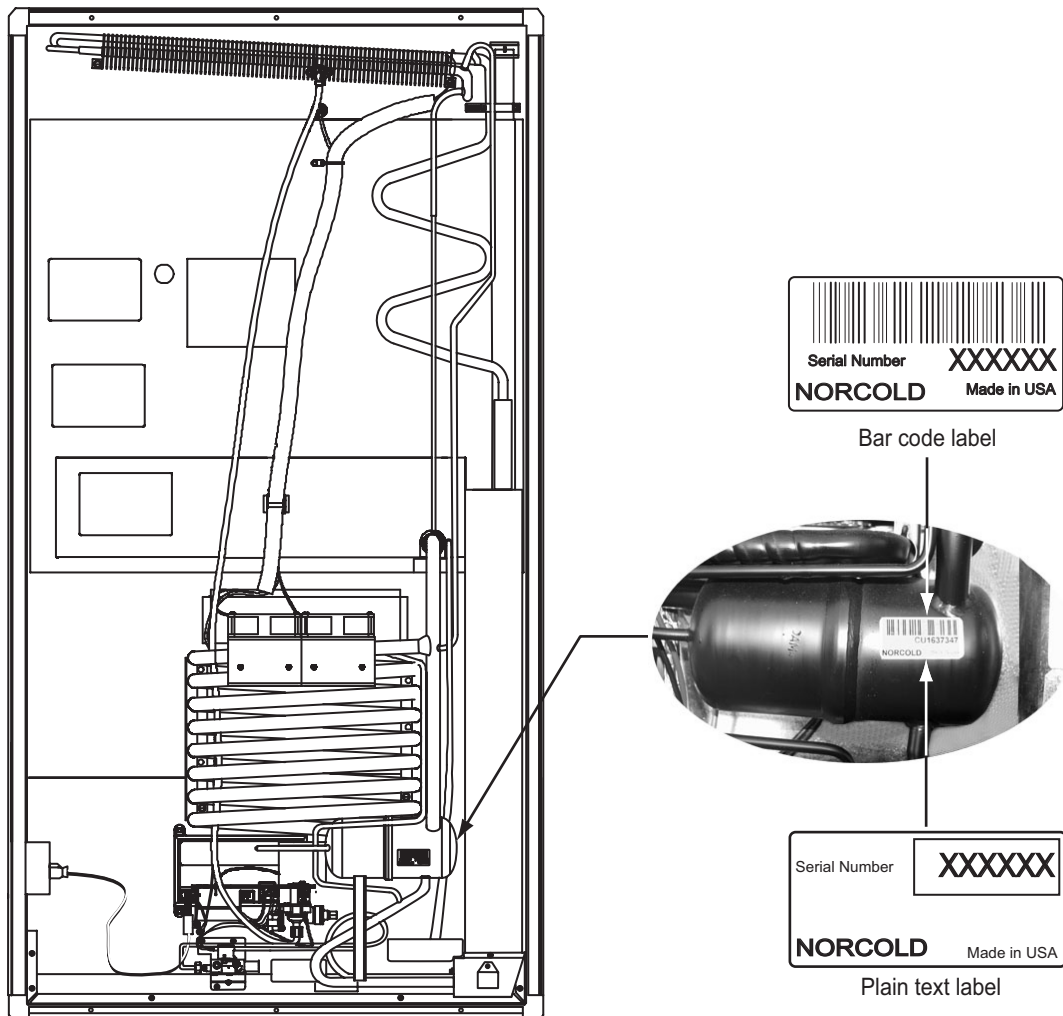

Figure 2. Cooling unit bar code label location

Safety Notice

It is not possible to anticipate all of the conceivable ways or conditions under which the refrigerator may be serviced or to provide cautions as to all of the possible hazards that may result. Standard and accepted safety precautions and equipment should be used when working on electrical circuits and handling toxic or flammable materials. Safety goggles and other required protection should be used during any process that can cause material to become airborne, such as removing a leaking cooling unit and cleaning components.

Attention Statements

The safety alert symbol  followed by the word **WARNING** or **CAUTION** identifies potential safety hazards or conditions.

The safety alert symbol with the appropriate heading

appears on all safety labels posted on the refrigerator and safety awareness notices presented throughout this manual.

WARNING

The above heading identifies hazards or conditions, which if ignored can cause serious injury, death, and/or extensive property damage.

CAUTION

The above heading identifies hazards, which if ignored can cause injury and/or property damage.

Safety Statements

 **Do not** modify, alter, or equip the refrigerator to the use of any other fuel (natural gas, butane, etc.). 1200 refrigerators are designed and equipped for the use of LP gas—*propane gas*—only.

 Incorrect installation, adjustment, alteration, or maintenance of the refrigerator can cause personal injury, property damage, or both.

 **Do not** smoke, light fires, or create sparks when working on the propane gas system.

 **Do not** use an open flame for leak testing any of the propane gas system components. Propane gas is highly flammable and explosive.

 Always use two wrenches to tighten or loosen LP gas connections. Damaged connections, piping, and components create the potential for gas leaks.

 All electrical connections and repairs to the refrigerator must comply with all applicable codes. Refer to the certification and code requirements section of the *1200XX/120X-IMXX Installation Manual* for more information.

 **Do not** work on live electrical circuits. Turn off AC power and DC power sources before attempting to remove, service, or repair any of the refrigerator's electrical or electronic components.

 **Do not** modify, bypass, or eliminate any of the refrigerator's electrical components, electronic circuits, or propane gas system components.

 **Do not** wet or spray liquids on or near electrical connections or electronic components. Most liquids, including leak detection solutions, are electrically conductive and pose the potential for an electric shock hazard, short electrical components, damage electronic circuits, and/or ignite a fire.

 **Do not** use leak test solutions that contain ammonia or chlorine. Ammonia and chlorine degrade copper and brass components.

 **Do not** try to repair or recharge the cooling unit. **Do not** bend, drop, weld, drill, puncture, saw, or strike the cooling unit.

 **Handle a leaking cooling unit with extreme caution!** The cooling unit contains ammonia, hydrogen, and sodium chromate. Ammonia can cause severe skin and eye burns. Hydrogen is highly flammable, can ignite, and burns with an intense flame. Certain chromium compounds, such as sodium chromate, are carcinogenic.

 **Do not** use extension cords. **Do not** remove the grounding prong from the refrigerator AC power cord. **Do not** use a two prong adapter to connect the refrigerator to the ac outlet.

 **Do not** over-fuse electrical circuits. Use specified fuses and AWG wire sizes. The "Specifications" section of this manual provides fuse size information. Refer to the *1200XX/120X-IMXX Installation Manual* for the correct AWG wire size specifications.

 **Prevent child entrapment!** Before disposing of the refrigerator, remove all doors and fasten all shelves with retainers.

 Some of the refrigerator's metal components have sharp corners and edges. Wear hand protection, such as cut resistant gloves, and exercise extreme care when handling the refrigerator.

 Make sure all hardware, such as hinges and fasteners (retaining screws, etc.), is properly fastened.

SPECIFICATIONS

1200XX/120X-IMXX Models

Storage volume

Freezer ----- 1.3 ft.³ each
Fresh food compartment ----- 8.0 ft.³

Rough opening dimensions (H x W x D)

1200XX/120X-IMXX ----- 63 1/4 in. x 32 11/16 in. x 24 in.

Decorative panels dimensions

Thickness ----- 3/16 in.
Freezer door (H x W) ----- 17 17/32 in. x 16 11/16 in. (each door)
Fresh food compartment door ----- 40 11/32 in. x 16 13/64 in. (each door)

Controls

Type ----- Electronic with built-in diagnostic function
ON/OFF/MODE/TEMP SET switches ----- Flush push-button style
Temperature settings ----- 1=cold, 9=coldest
Temperature sensor ----- Thermistor, fin-mounted

Off-level operating limits

Side-to-side ----- 3 degrees maximum
Front-to-back ----- 6 degrees maximum

DC power

Controls operating voltage ----- 10.5 to 15.4 Vdc
DC fuse (F1 in power board) -----
Units with serial numbers 51660 and lower ----- 3 A (violet color), automotive blade type
Units with serial numbers 51661 to 8321171 ----- Two, 3 A (violet color), automotive blade type
Units with serial numbers 8321172 and higher ----- 5 A (tan color), automotive blade type

DC amp draws (at nominal 12 Vdc)

Automatic ignition ----- 0.50 A
Moisture reduction heater and divider heater ----- 0.70 A
Fresh food compartment lamp ----- 0.46 A
Gas valve ----- 0.146 A
Fans (2) ----- 0.30 A (per fan)

AC power

AC heater operating voltage requirements ----- 108 to 132 Vac
Fuse AC heater circuit (F3 in power board) ----- 5 A, 1/4 in. x 1 1/4 in. AGC type fast acting
AC heater rating ----- 225 W @ 120 Vac (resistance of 64 Ω)

LP gas (propane)

Operating pressure ----- 10.5 to 11.5 in. w.c.
Heat input ----- 2200 Btu/h @ 11 in. w.c.
Orifice, old style ----- 0.190 jeweled
Orifice, new style ----- LP18
Gas ignition ----- Automatic with flame sensing circuit
Electrode tip-to-burner air gap ----- 1/8 to 3/16 in.

TROUBLESHOOTING – QUICK REFERENCE GUIDE

Problem	Possible Cause	Checks/Reference
The refrigerator does not turn ON.	No 12 VDC power to refrigerator. Faulty/loose 12 Vdc connections. F1 fuse in power board open.	See page 9. Check 12 volt DC connections. Check F1 fuse.
The refrigerator does not cool on AC power.	No AC power to refrigerator. F3 fuse in power board open. AC heater failed open.	See page 13. Check F3 fuse. Check heaters resistance and continuity.
The refrigerator does not cool efficiently on AC power.	Ventilation obstructed. AC voltage low.	Check enclosure for air flow obstructions. Check AC voltage input.
The refrigerator does not operate on LP gas.	No LP gas. Incorrect electrode-to-burner gap. Faulty spark/sense electrode assembly. Flame sensing circuit failure.	Check LP gas supply and valves. Set electrode to 1/8 to 3/16 in. Replace spark/sense electrode. Replace power board. See page 40.
The refrigerator does not cool efficiently on LP gas.	Ventilation obstructed. Incorrect LP gas pressure. Dirty burner. Missing flue baffle. Flue cap blocked.	Check enclosure for obstructed air flow. Set gas pressure to 10.5 to 11.5 in. w.c. Clean burner. See page 27. Replace flue baffle. See page 27. Clear flue cap. See page 27.
Poor or no cooling.	Poor ventilation. Off-level operation. Dirty burner. Low AC voltage. Cooling fan inoperative (if present). Improper installation. Incorrect orifice.	Check enclosure for obstructed air flow. Level unit. See page 32. Clean burner. See page 28. Check AC voltage input. Test fan operation. Check installation. See pages 19-23 and <i>1200 Installation Manual</i> . Install correct orifice (see Specifications).

DISPLAYED FAULT CODES: S/N 832170 & LOWER

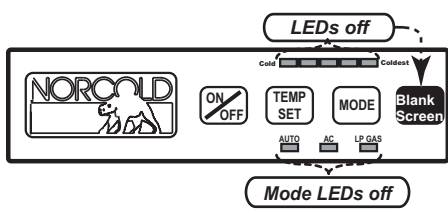
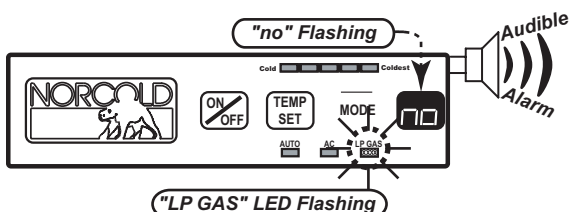
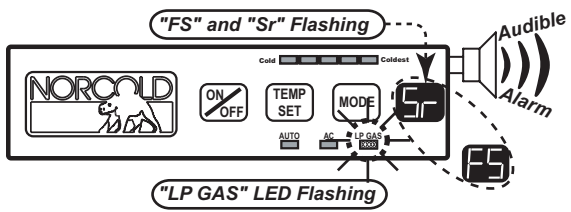
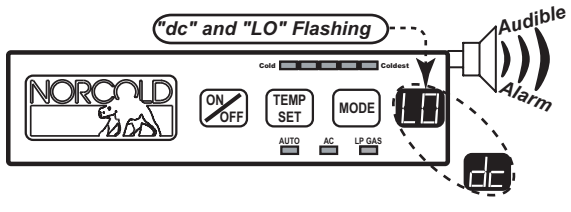
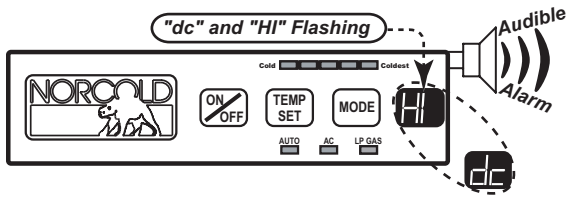
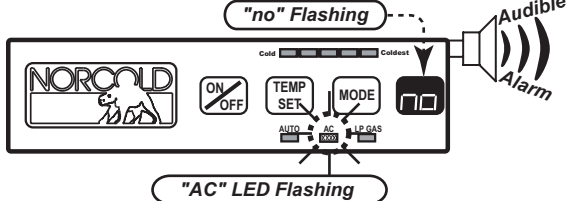
Code	Probable Cause	Reference
 <p>LEDs off</p> <p>Mode LEDs off</p>	<p>Refrigerator turned off. No 12 VDC to power board. F1 fuse open.</p>	<p>See page 9.</p>
 <p>"no" Flashing</p> <p>"LP GAS" LED Flashing</p> <p>Audible Alarm</p>	<p>Burner failed to ignite or re-ignite</p>	<p>See page 10.</p>
 <p>"FS" and "Sr" Flashing</p> <p>"LP GAS" LED Flashing</p> <p>Audible Alarm</p>	<p>Flame sense circuit failure</p>	<p>See page 11.</p>
 <p>"dc" and "LO" Flashing</p> <p>"LP GAS" LED Flashing</p> <p>Audible Alarm</p>	<p>DC voltage low</p>	<p>See page 11.</p>
 <p>"dc" and "HI" Flashing</p> <p>"LP GAS" LED Flashing</p> <p>Audible Alarm</p>	<p>DC voltage high</p>	<p>See page 12.</p>
 <p>"no" Flashing</p> <p>"AC" LED Flashing</p> <p>Audible Alarm</p>	<p>No AC power to refrigerator. AC cord not plugged into power board. F3 fuse open.</p>	<p>See page 13.</p>

Code

Probable Cause

Reference

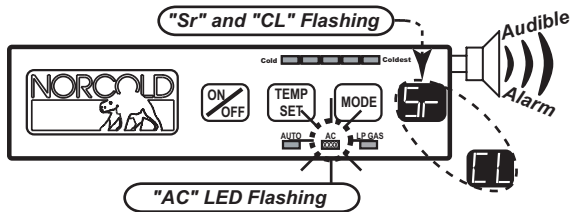

AC relay stuck closed.

See page 12.

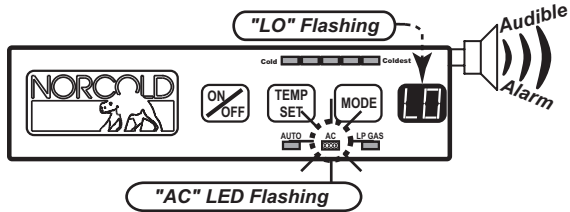

AC voltage low.

See page 14.

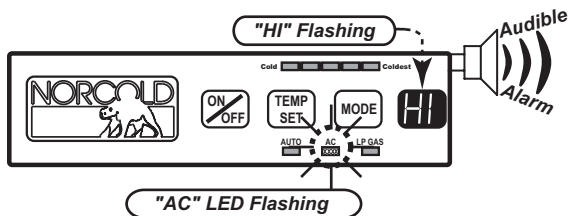

AC voltage high.

See page 14.

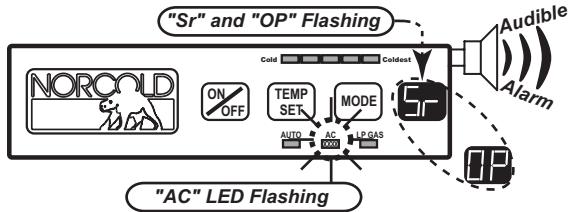

AC heaters failed open.

See page 15.

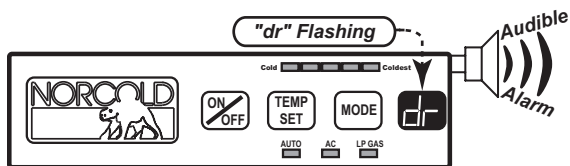

Fresh food compartment door open more than 2 minutes.

See page 16

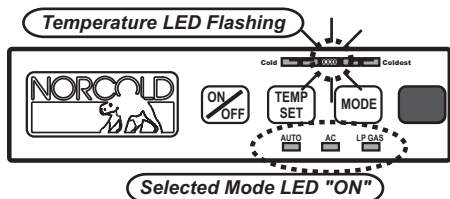

Thermistor open, BOS operation.

See page 17.

DISPLAYED FAULT CODES: S/N 832171 & HIGHER

Code	Probable Cause	Reference
Blank Display Screen	Refrigerator turned off. No 12 Vdc to refrigerator. F1 fuse open.	See page 9.
no. FL. (Alternating Display, Audible Alarm)	The burner failed to ignite or reignite.	See page 10.
Er. (Audible Alarm)	Flame sense circuit failure.	See page 11.
dc. LO. (Alternating Display, Audible Alarm)	DC voltage low.	See page 11.
dc. HI. (Alternating Display, Audible Alarm)	DC voltage high.	See page 12.
no. AC. (Alternating Display, Audible Alarm)	No ac power available to refrigerator. AC cord not plugged into power board. F3 fuse open.	See page 13.
AC. rE. (Alternating Display, Audible Alarm)	AC relay stuck closed.	See page 12.
AC. LO. (Alternating Display, Audible Alarm)	AC voltage low.	See page 14.
AC. HI. (Alternating Display, Audible Alarm)	AC voltage high.	See page 14.
AC. HE. (Alternating Display, Audible Alarm)	AC heater failed open.	See page 15.
dr. (Audible Alarm)	Fresh food compartment door open more than 2 minutes. Lamp reed relay switch faulty.	See page 16.
Flashing Temp Setting	Backup operating system in operation.	See page 17.
no. ca. (Alternating Display, Audible Alarm)	No cooling detected by the controls.	See pages 18 , 32, and 35.

Blank Display – Refrigerator does not turn on

Before beginning this procedure make sure:

- The RV DC power system is supplying 10.5 to 15.4 volts to the refrigerator.
- No other RV appliances or lighting circuits are connected to the refrigerator DC circuit.
- 12 VDC input to the power board is wired according to the 1200XX/120X-IMXX Installation Manual.

Fault indicator displayed:

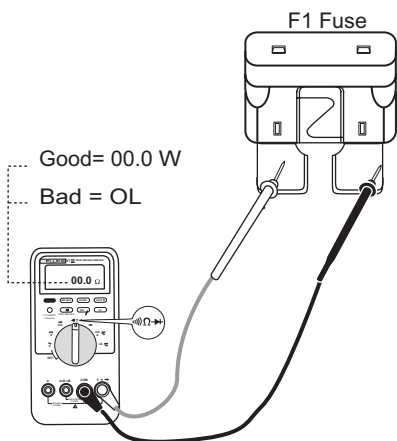
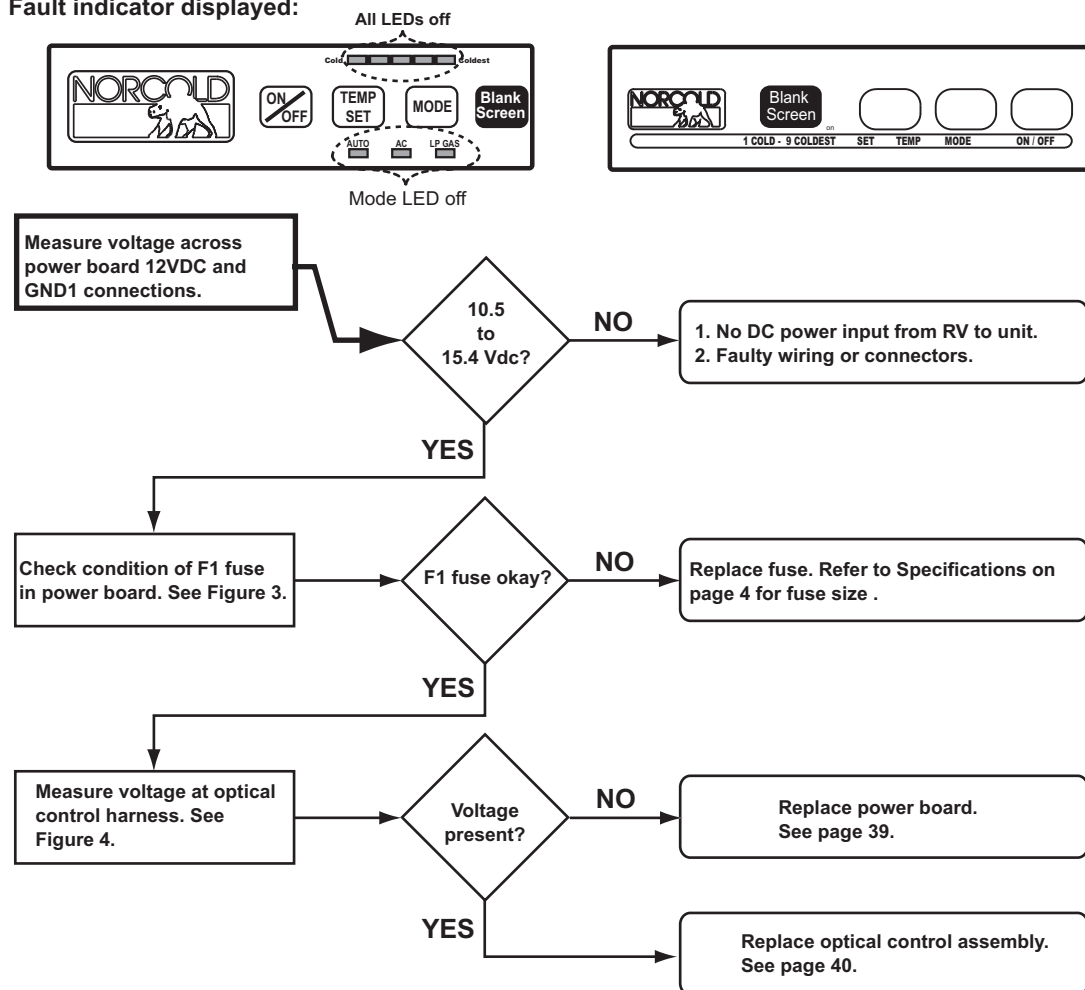

Figure 3. Checking the DC fuse continuity.

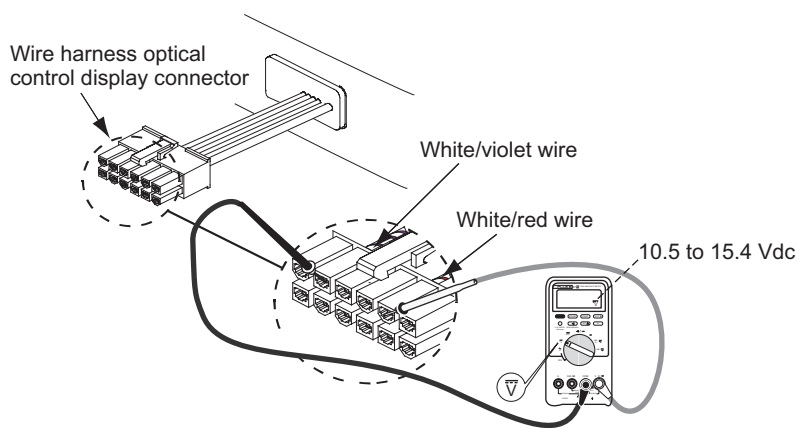

Figure 4. Measurement points for wire harness voltage.

"no" "LP" / "no" "FL" Fault Code – Burner failed to ignite/re-ignite

Before beginning this procedure make sure:

- RV LP gas tank valve is open.
- Refrigerator solenoid gas valve manual shut-off is open.
- LP gas pressure at the solenoid gas valve pressure tap is 10.5 to 11.5 in. w.c.

Fault indicator displayed:

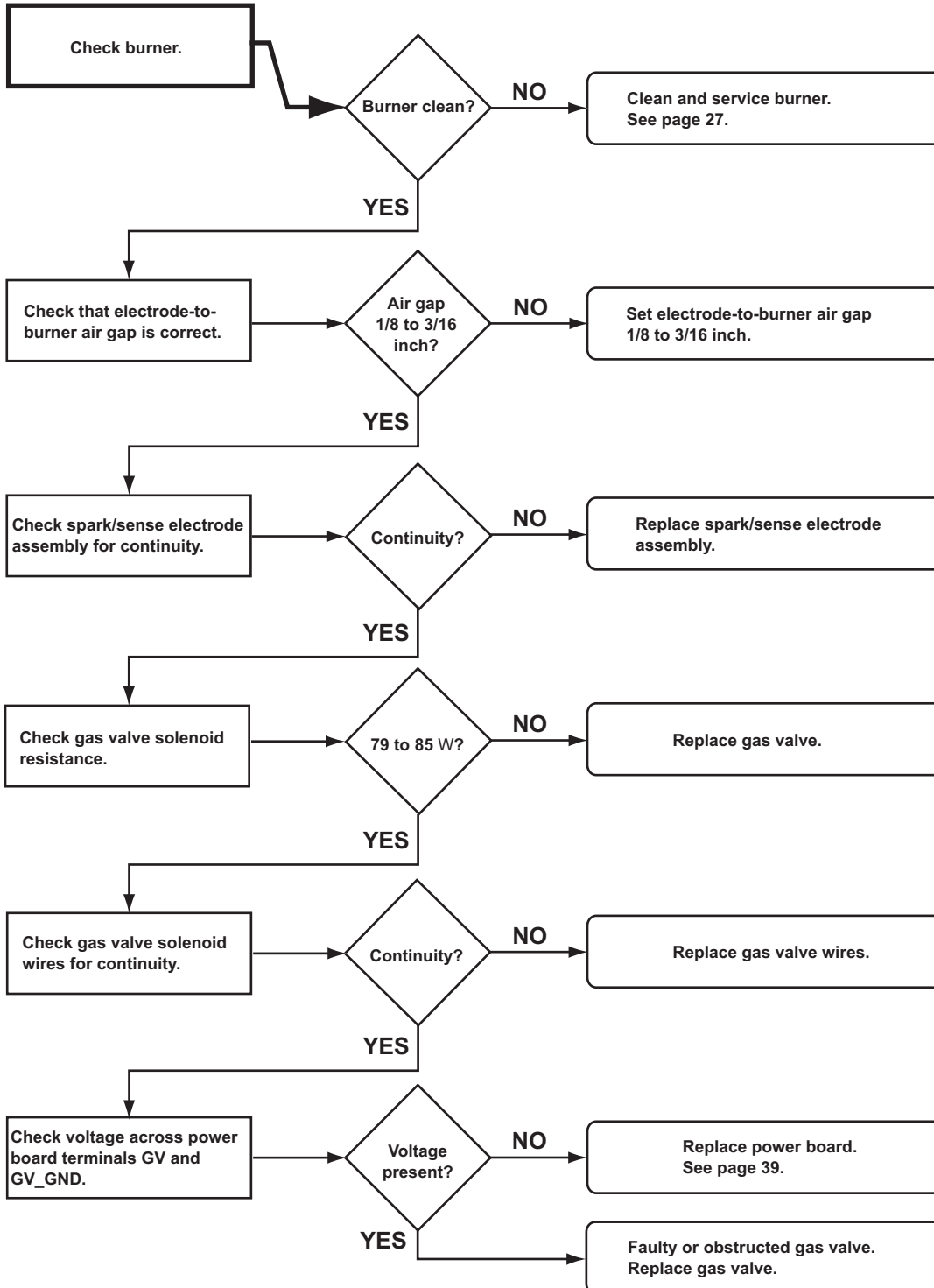
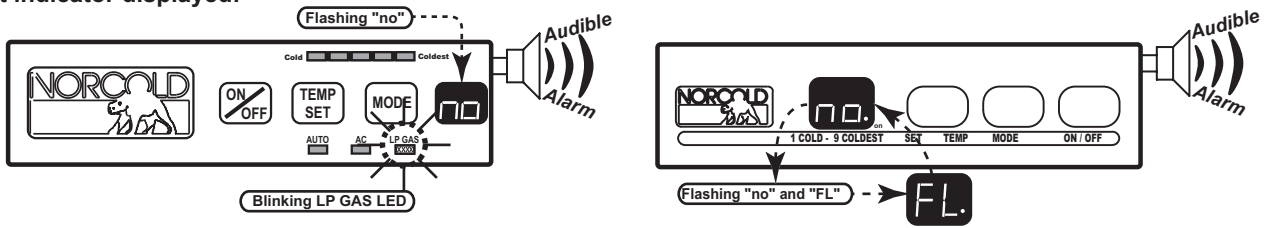

"Sr" "FS"/"Sr" Fault Code – Flame sense circuit failure

Fault indicator displayed:

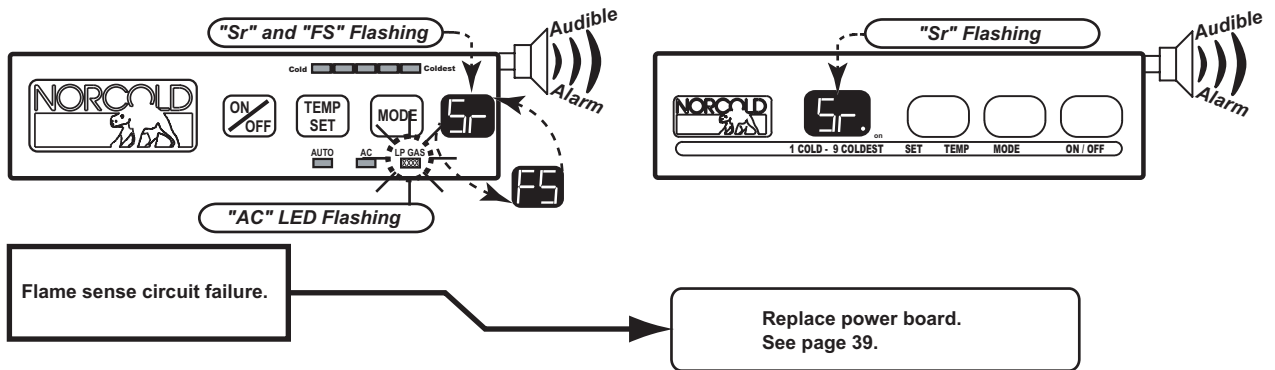

"dc" "LO" Fault Code –dc voltage input to power board is lower than 10.5 volts

Before beginning this procedure:

- Make sure RV DC voltage to refrigerator is at least 10.5 and no more than 15.4 volts.
- Determine if the "dc LO" fault code displays when the converter is the source of DC power.
- Make sure no other appliance or lighting circuit is connected to the refrigerator DC circuit.

Fault indicator displayed:

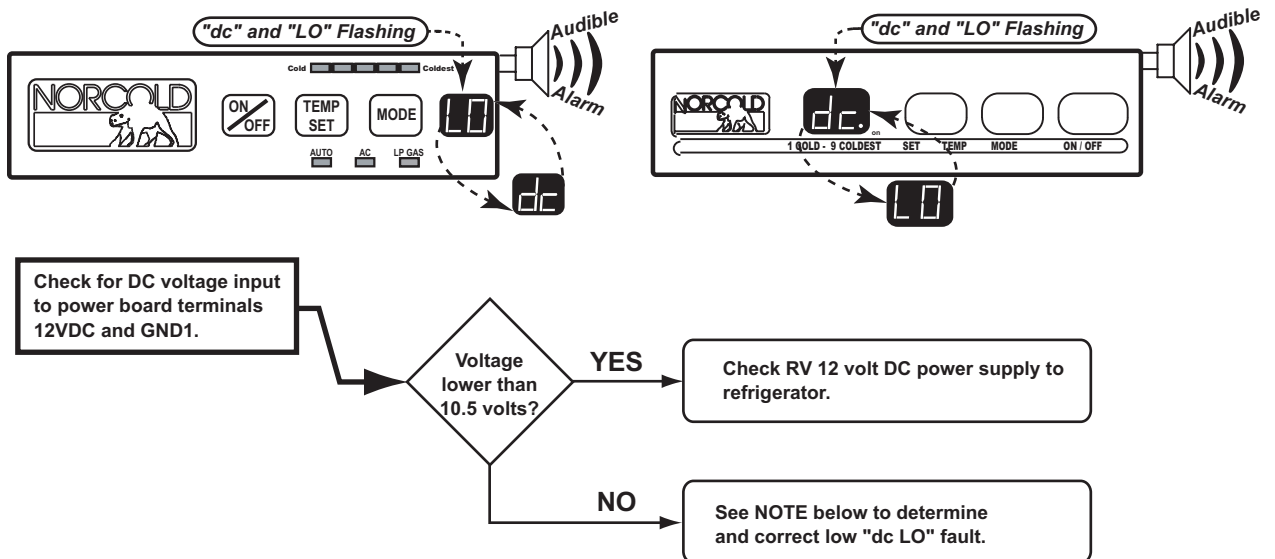

NOTE

Electronic controls operate on 12 volt DC. When an AC/DC converter is used to supply DC power, the refrigerator circuit must be connected to the appliance output terminals of the converter (filtered side).

If the refrigerator circuit is connected to the unfiltered side, the AC ripple generated by the converter may cause a "dc LO" fault code to display.

To troubleshoot a "dc LO" fault, connect a charged 12 volt automotive battery to the power board. If the "dc LO" code clears, the fault was caused by unfiltered DC power.

If the "dc LO" code does not clear, replace the power board (see page 39).

"dc" "HI" Fault Code – DC voltage input to power board is higher than 15.4 volts

Before beginning this procedure:

- Make sure RV DC voltage to refrigerator is 10.5 to 15.4 volts.
- Determine if the "dc" "HI" fault code displays when the converter is the source of DC power.

Fault indicator displayed:

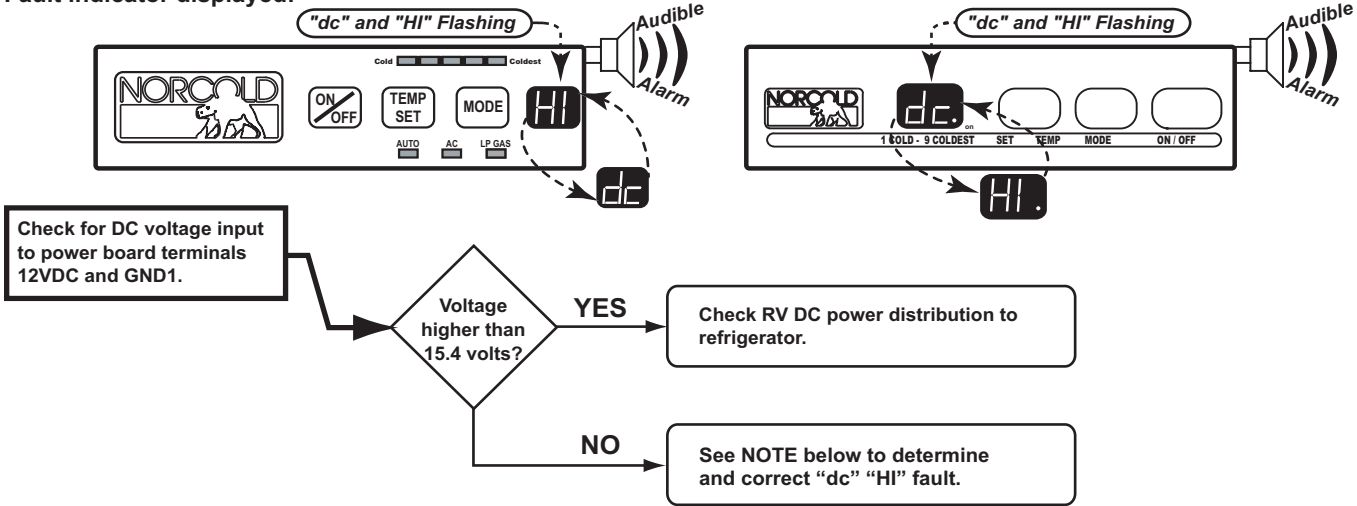

NOTE

Electronic controls operate on 12 volt DC. When an AC/DC converter is used to supply DC power, the refrigerator circuit must be connected to the appliance output terminals of the converter (filtered side).

If the refrigerator circuit is connected to the unfiltered side, the AC ripple generated by the converter may cause a "dc HI" fault code to display.

To troubleshoot a "dc HI" fault, connect a charged 12 volt automotive battery to the power board. If the "dc HI" code clears, the fault was caused by unfiltered DC power. If the "dc HI" code does not clear, replace the power board (see page 39).

"Sr" "CL"/"AC" "rE" Fault Code –AC relay stuck closed

Fault indicator displayed:

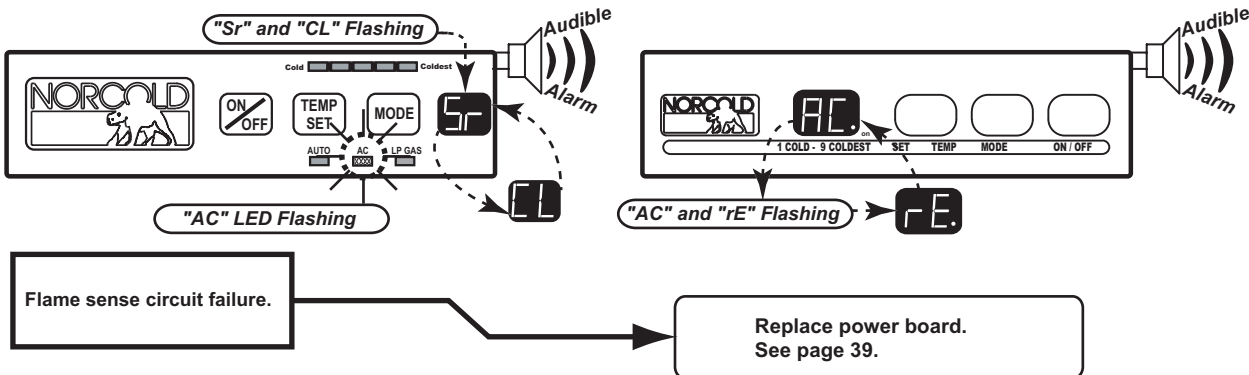

"no" "AC" Fault Code – No AC power available

Before beginning this procedure make sure:

- No other problems exist with the RV AC power supply.
- No other appliances or lighting circuits are connected to the refrigerator AC circuit.
- Extension cords are not being used to supply AC power to the refrigerator.

Fault indicator displayed:

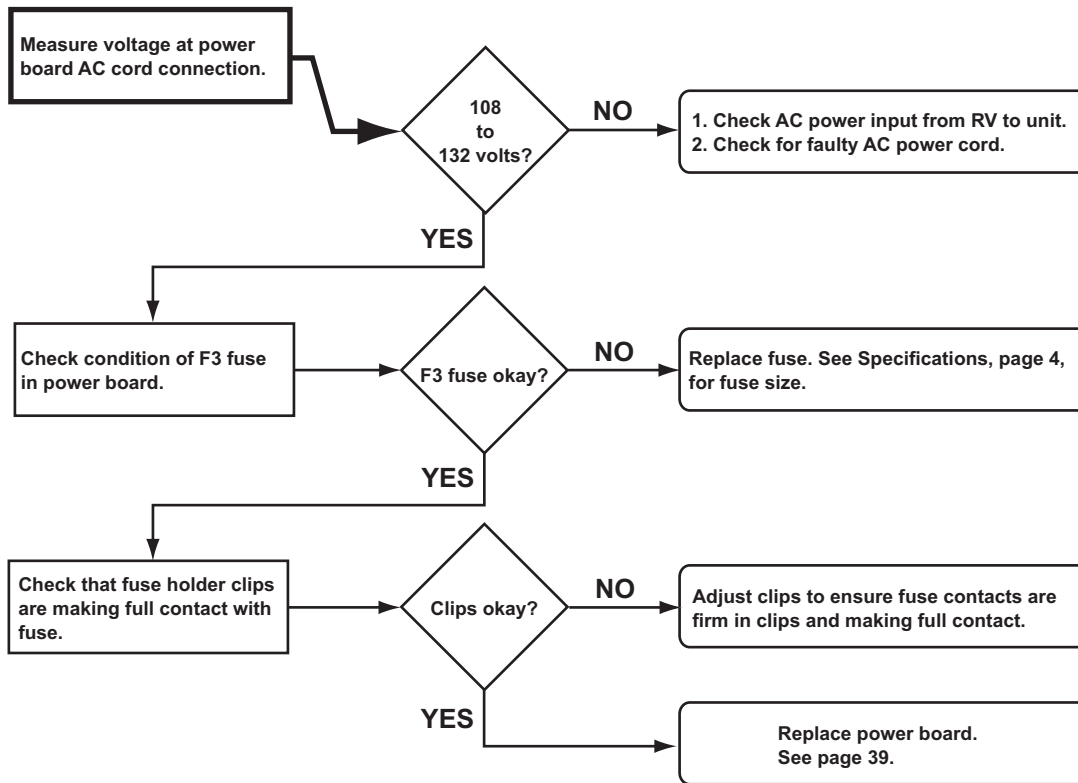
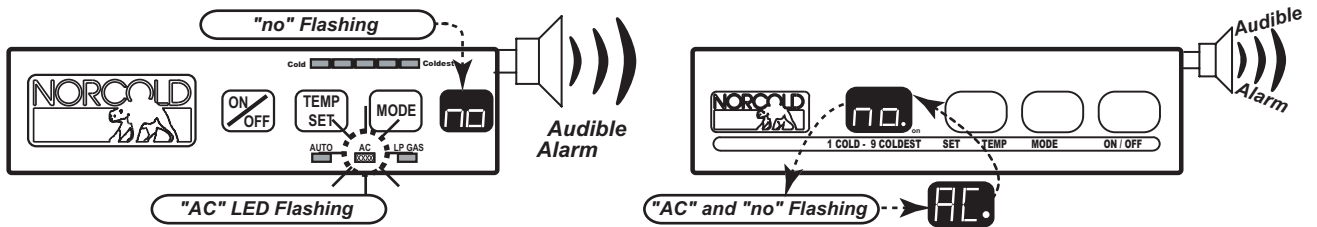

"AC" "LO" Fault Code – AC voltage low

Before beginning this procedure:

- Determine if a certain AC power source sets the "AC LO" fault code (generator, shore power, inverter).
- Make sure no other appliance or lighting circuit is connected to the refrigerator AC circuit.
- Make sure extension cords are not being used to supply AC power to the refrigerator.

Fault indicator displayed:

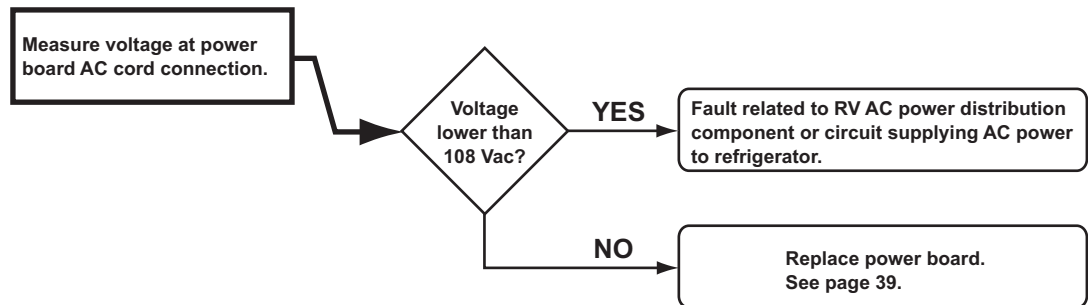
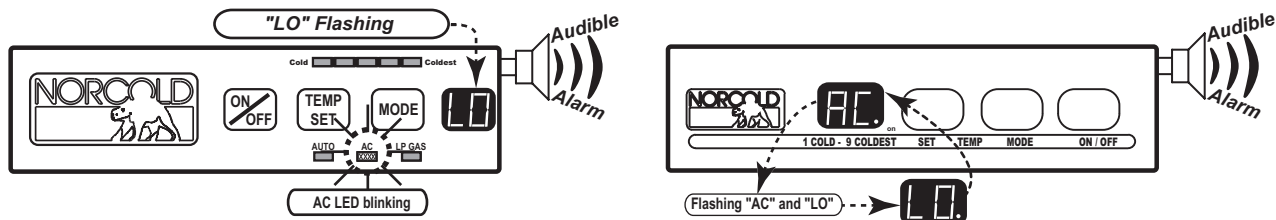

"AC" "HI" Fault Code – AC voltage high

Before beginning this procedure:

- Determine if a certain AC power source sets the "AC HI" fault code (generator, shore power, inverter).

Fault indicator displayed:

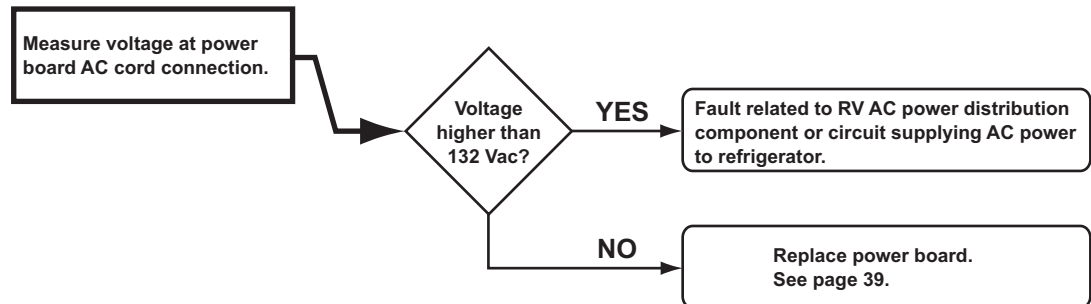
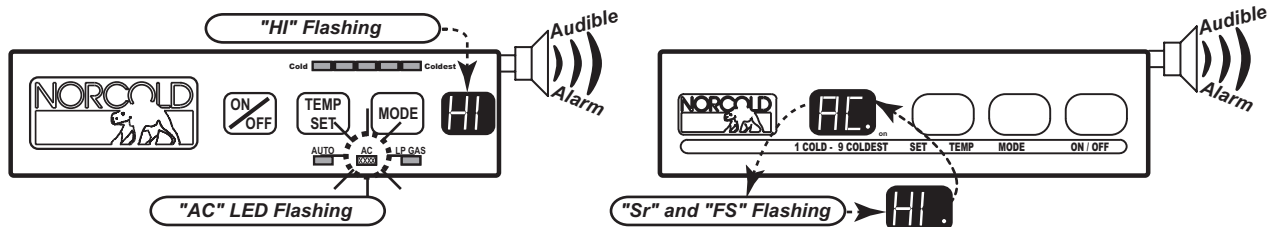

"AC" "HE" Fault Code – AC heaters failed open

Before beginning this procedure make sure:

- RV AC voltage to the refrigerator is 108 to 132 volts.
- No other appliance or lighting circuit is connected to the refrigerator AC circuit.

Fault indicator displayed:

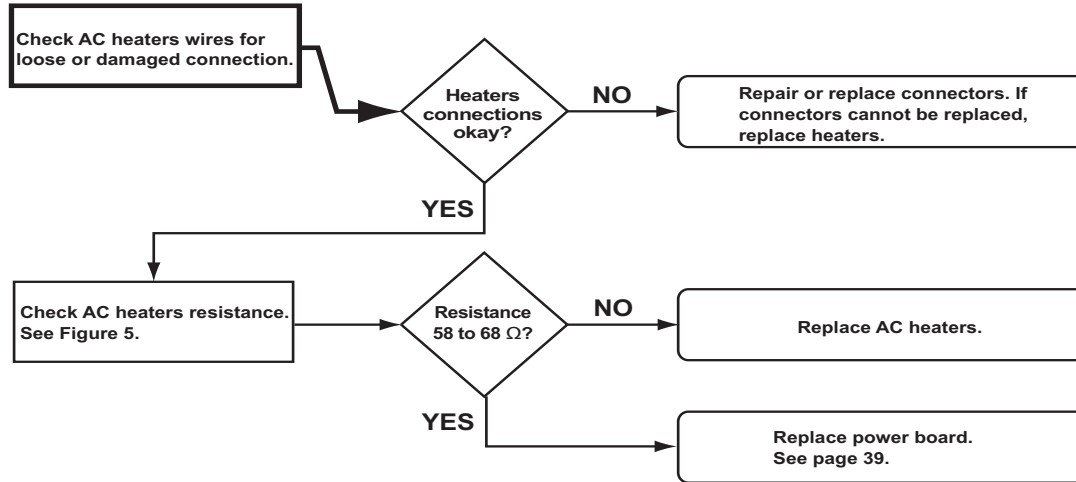
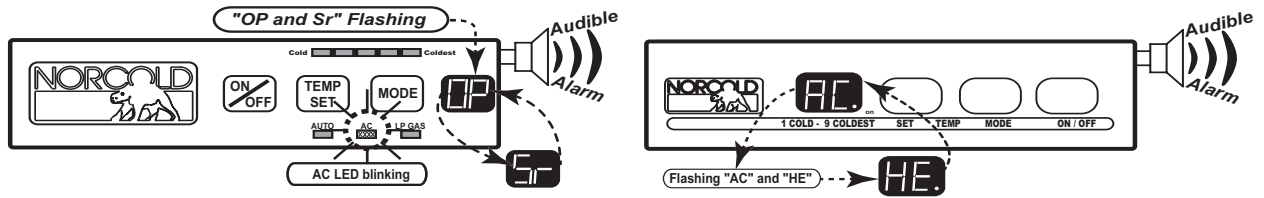

58 to 68 Ω
each heater
at room temperature

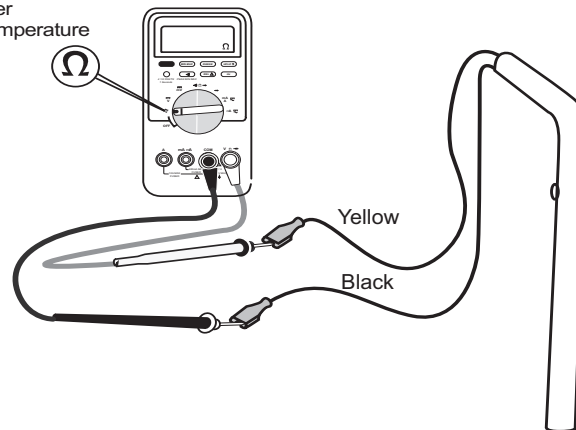

Figure 5. Checking AC heater resistance

"dr" Fault Code – Door open for more than 2 minutes

Before beginning this procedure make sure:

- Light/thermistor connector and wire harness connector are fully engaged and locked.

Fault indicator displayed:

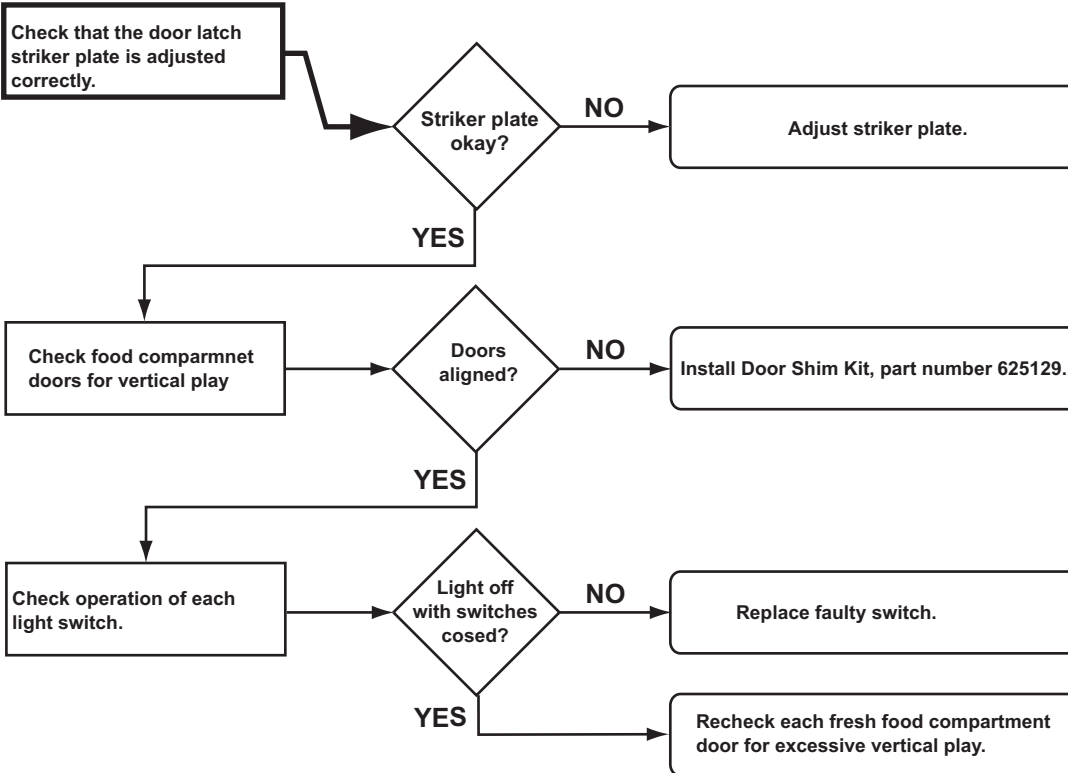

Thermistor Open – Controls in Backup Operating System mode

Before beginning this procedure:

- Make sure lamp/thermistor assembly is connected to the wire harness.

Fault indicator displayed:

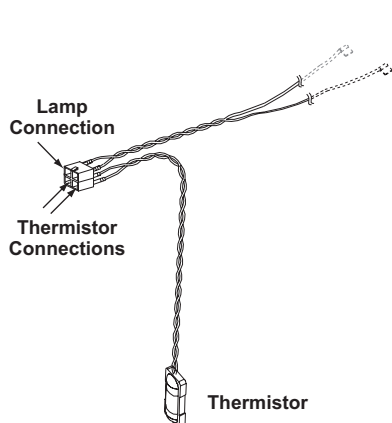
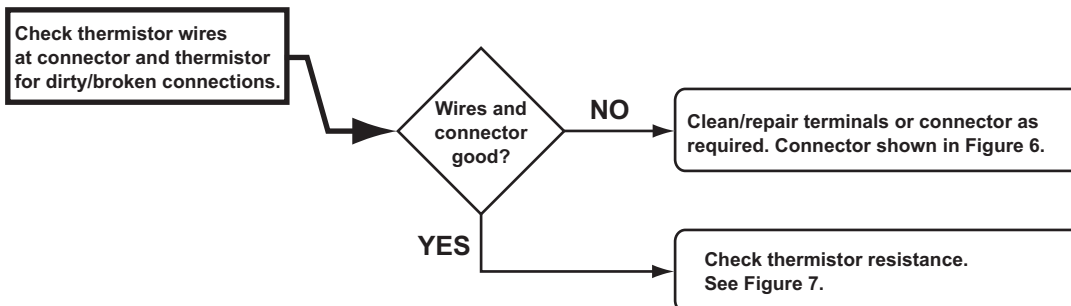
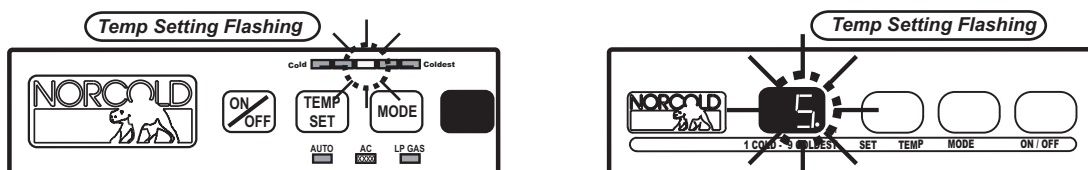
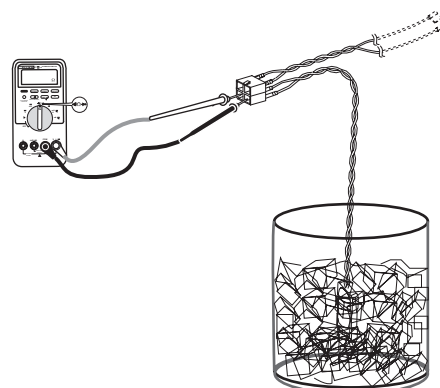

Figure 6. Thermistor terminals and connector.



Thermistor packed in ice bath

Figure 7. Checking thermistor resistance.

Temperature* (°F)	Resistance* (kΩ)
85	8.1– 9.0
80	9.1–10.0
75	10.1–11.0
70	11.1–12.0
60	12.1–13.0
50	15.5–16.5
40	22.5–23.5
35	24.5–25.5
33	28.5–29.5
32	30.0–32.0

*Approximate Values

Backup Operating System (BOS)

The backup operating system (BOS) is an electronically controlled duty cycle. It maintains the refrigerator in operation if the thermistor is disconnected or fails. The BOS maintains cooling by controlling the heat source selected. When the refrigerator is operating in BOS, the cooling cycle is regulated by a timer instead of the temperature sensing circuit.

To accomplish this, the BOS adjusts the length of the cooling cycle according to the temperature setting selected by the user; the higher the temperature setting, the longer the cooling cycle. For example, if the temperature setting is set to 5, raising the setting to 6 will lengthen the cooling cycle, making the cabinet colder.

When a warmer temperature is desired, changing the temperature setting to a lower number shortens the

cooling cycle. For example, if the temperature setting is set to 6, lowering the setting to 5 will shorten the cooling cycle.

1200XX/120X-IMXX Backup Operation, S/N 832170 and Lower

When the 1200XX/120X-IMXX controls shift to BOS operation, the optical control display assembly temperature setting indicating LED blinkd constantly at one blink every three seconds.

1200XX/120X-IMXX Backup Operation, S/N 832171 and higher

When the 1200XX/120X-IMXX controls shift to BOS operation, the temperature setting BLINKS for ten seconds when the TEMP button is pressed. After ten seconds, the "ON" LED displays. This action repeats any time the TEMP SET switch button is pressed.

"no" "co" Fault Code* – No cooling detected by the controls - S/N 832171 and higher

Fault indicator displayed:

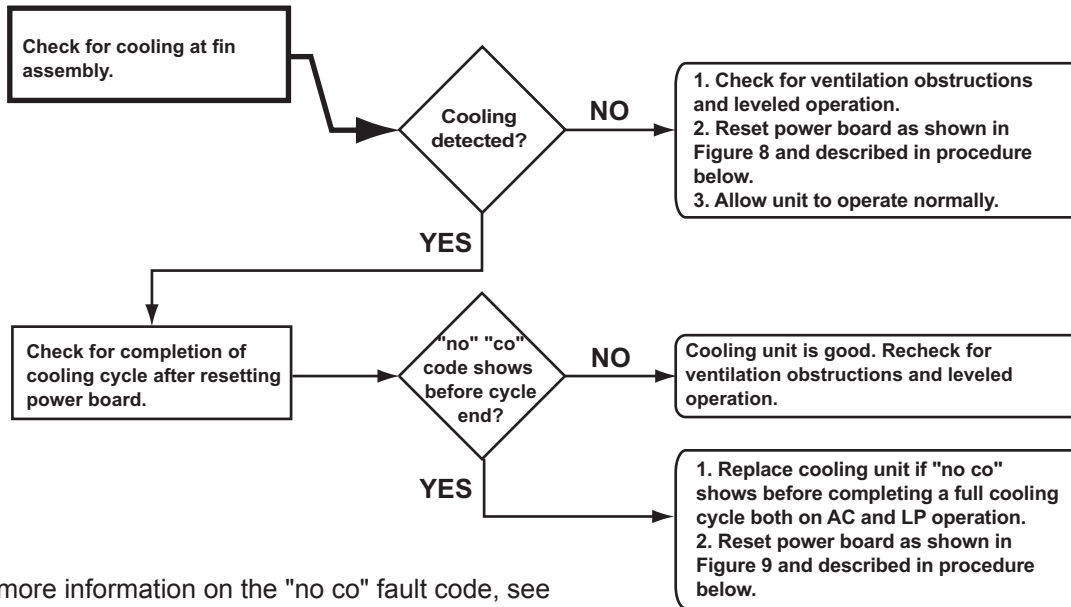
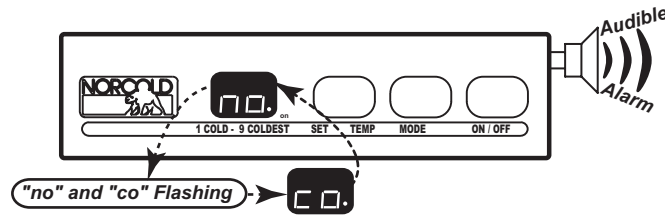

* For more information on the "no co" fault code, see pages 31-34.

Power Board Resetting Procedure

1. Turn OFF the refrigerator.
2. Disconnect the following from power board:
 - a. 12 VDC positive and negative wires.
 - b. AC power cord.
 - c. Gas valve solenoid coil wires.
 - d. Spark/sense electrode assembly wires.
3. Remove the power board cover.
4. Reconnect a,b,c,d disconnected in step 2
5. Turn ON the refrigerator.
6. Locate Pin 15 on 16 pin connector (P1). Pin 15 is the empty socket to the right of the white/violet wire on the top row. See Figure 8.
7. Using an insulated jumper wire, short Pin 15 to the power board ground lug for 10 - 15 seconds (see Figure 9). A click sound will indicate when the controls have reset.
8. Turn OFF the refrigerator.
9. Turn ON refrigerator. If "no co" code displays, repeat steps 7 - 9. If the code cleared proceed to step 10.
10. Turn OFF the refrigerator.
11. Disconnect a,b,c, and d. as directed in step 2.
12. Install the power board cover.
13. Reconnect the following to the power board:
 - a. Spark/sense electrode assembly wire.
 - b. Gas valve solenoid coil wires.
 - c. AC power cord.
 - d. 12 VDC positive and negative wires from the power board.
14. Place refrigerator in service.

NOTE
A jumper wire to short Pin 15 to ground can be made from a six inch long insulated **14 AWG** wire with a **1/2** inch of insulation stripped from each end.

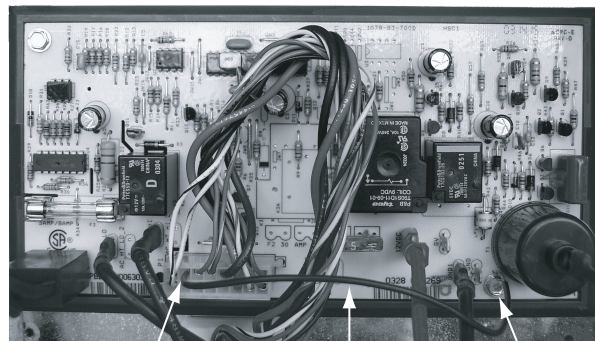

Pin 15 Jumper Wire Ground

Figure 9. Resetting the power board.

Roof Exhaust Venting

NOTE

The general guidelines for intake vents and roof exhaust vents presented in this section do not replace the instructions and/or guidelines provided in the *1200XX/120X-IMXX Installation Manual* and the *Ventilation Guidelines For Gas/Electric Refrigerators*, part number 622090A (3-01). Refer to the *1200XX/120X-IMXX Installation Manual* and *Ventilation Guidelines For Gas/Electric Refrigerators* for the latest information on approved vents, installation instructions, and special construction exceptions.

Air Intake Vent

The ventilation and combustion air flows into the enclosure through the air intake vent. See Figure 9.

The space between the air intake vent and the rear of the refrigerator must be kept clear at all times. Any obstruction in this area may cause serious ventilation problems. The air intake vent opening also provides access for servicing cooling unit components.

Roof Exhaust Vent

The heat absorbed by ventilation air and combustion gases flow out of the enclosure through the roof exhaust vent. See Figure 9.

The roof exhaust vent is equipped with a non-removable metal mesh screen that prevents leaves, debris, birds or rodents from getting into the enclosure. The roof cap is fastened to the exhaust vent with four screws. The cap is always installed with the slope towards the front of the RV.

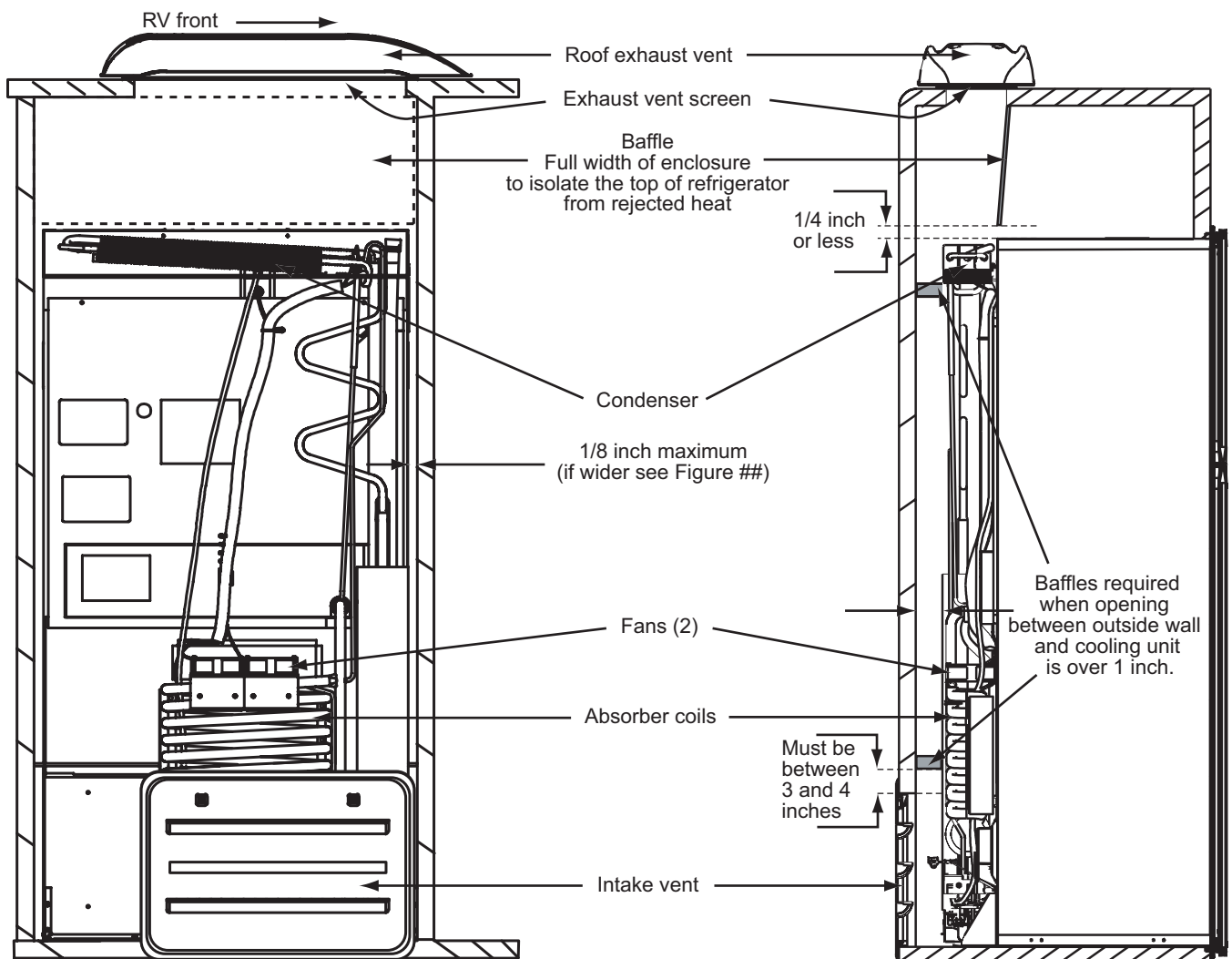

Figure 9. Roof exhaust venting arrangement.

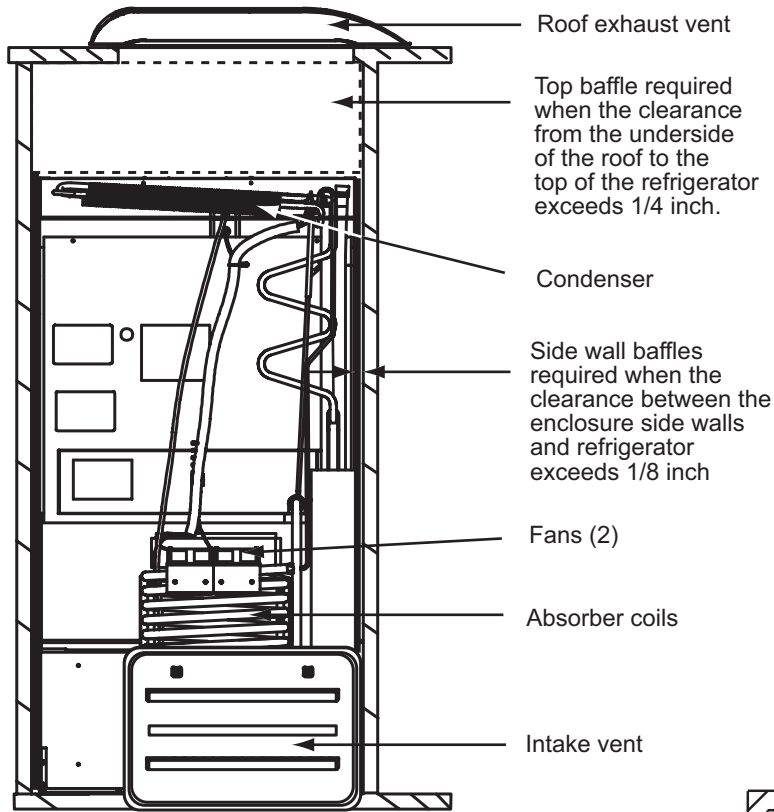

Figure 10. Back view—roof exhaust venting

Baffles

The minimum and maximum clearances for installing the refrigerator or correcting ventilation problems on roof vented units are listed in Table 1 below. Baffles are required whenever installations exceed maximum clearances listed in Table 1. Figure 10 and Figure 11 show baffle locations.

Vertical Angled Baffles

Vertical angled baffles are required when the roof exhaust vent is installed inboard of the condenser. Figure 12 shows the angled vertical baffles required on inboard roof vent installations. The horizontal wall baffles are required whenever the distance between the cooling unit and the interior surface of the outside wall exceeds one inch.

	Minimum	Maximum
Bottom	0 inch	0 inch
Sides (each)	0 inch	1/8 inch
Top	0 inch	1/4 inch
Rear	0 inch	1 inch

Table 1. Clearances for roof vented installations

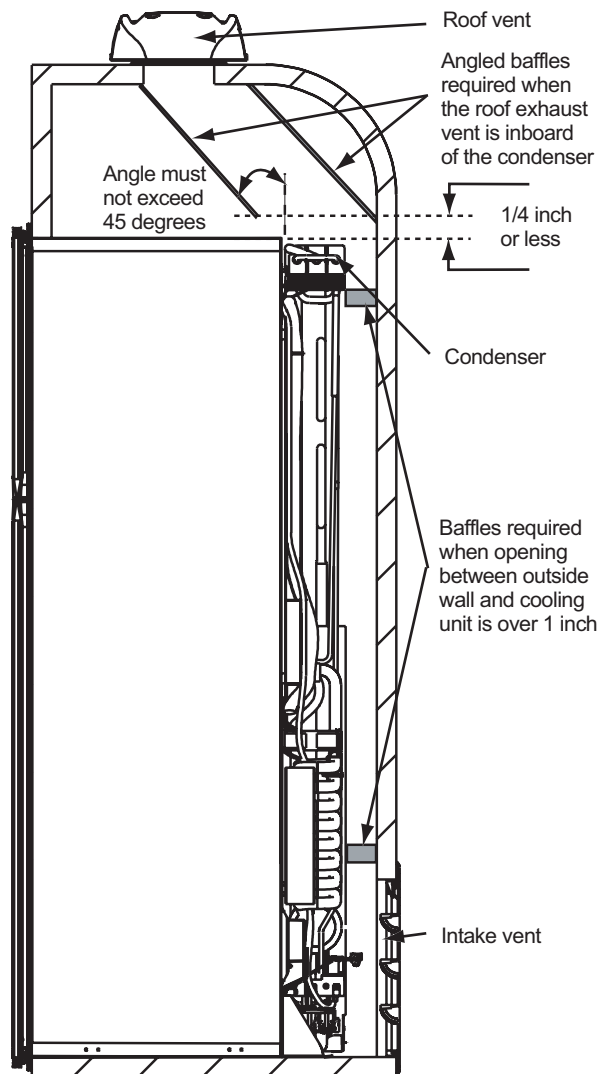

Figure 11. Baffles required for an inboard roof exhaust vent installation

Double Sidewall Venting

NOTE

The general guidelines for intake vents and roof exhaust vents presented in this section do not replace the instructions and/or guidelines provided in the *1200XX/120X-IMXX Installation Manual* and the *Ventilation Guidelines For Gas/Electric Refrigerators*, part number 622090A (3-01). Refer to the *1200XX/120X-IMXX Installation Manual* and *Ventilation Guidelines For Gas/Electric Refrigerators* for the latest information on approved vents, installation instructions, and special construction exceptions.

Because of increased installation of refrigerators in RV slide outs, NORCOLD has developed venting guidelines for double sidewall vent applications. This ensures NORCOLD refrigerators meet the ANSI Z21.19 standards for cooling performance when used in slide out applications.

The challenge with slide out installations is that the "chimney effect" (see page 31) that is present with roof vent installations is not as strong in slide outs. To improve the airflow of the chimney effect, sidewall vent installations must have fans and baffles. These fans and baffles direct the air flow through the surfaces of heat rejecting components. NORCOLD has determined that the following three key design considerations optimize heat removal in slide out applications.

- Refrigerators installed in slide outs must have a fan or fans to assist air flow. All 1200XX/120X-IMXX refrigerators have two factory installed fans.
- Fresh air must be directed to flow through the surface areas of the absorber coils, condenser fins, and the outer surface of the canister.
- Corners and structural pockets where heated air may stagnate must be reduced in size or completely eliminated.

Two baffles are required for the 1200XX/120X-IMXX model in double sidewall venting applications. It should be noted that baffle arrangements are different if the enclosure depth is greater or less than 26 inches. The baffle configurations are shown in Figure 13, page 21, and Figure 14, page 22.

Air Intake Vent

The ventilation and combustion air flow into the enclosure is through the air intake vent. See Figure 12, page 22, and Figure 13, page 23.

Sidewall Exhaust Vent

The heat absorbed by ventilation air and combustion gases flow out of the enclosure through the sidewall exhaust vent. See Figure 12, page 22, and Figure 13, page 23 for details.

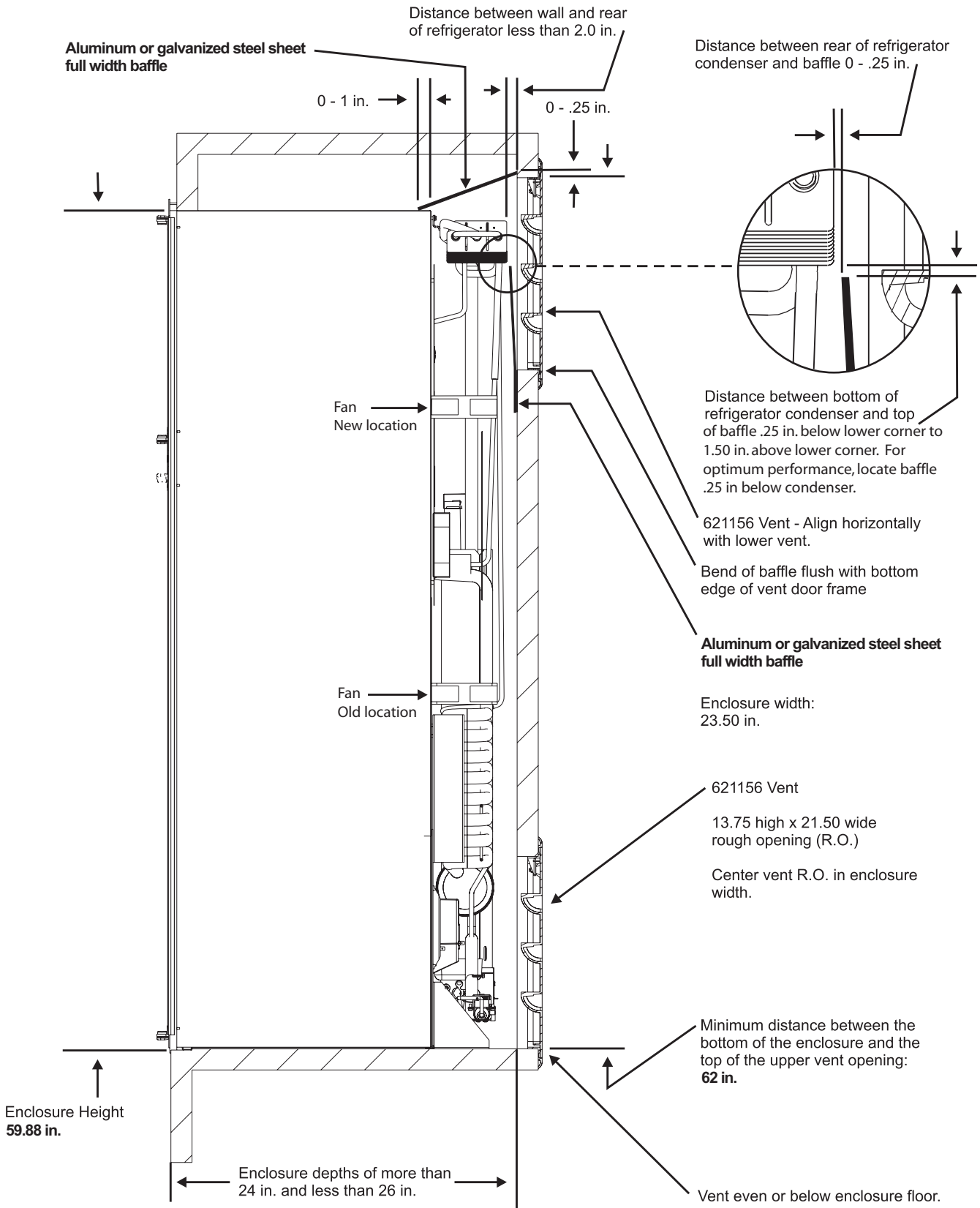

Figure 13. Baffle arrangement for enclosures depths of more than 24 inches and less than 26 inches

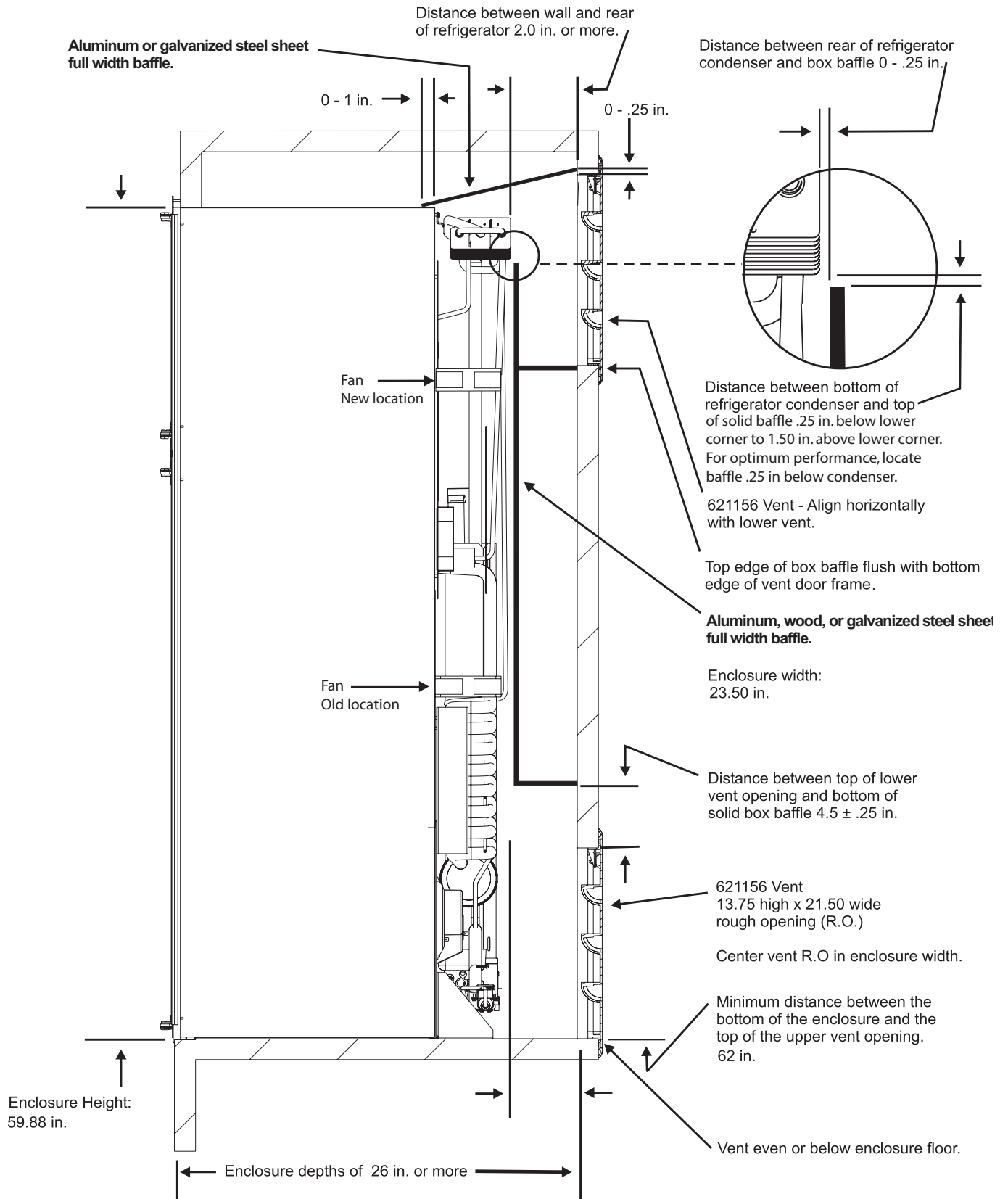

Figure 14. Baffle arrangement for enclosures with depths of 26 inches or greater

LP GAS SYSTEM

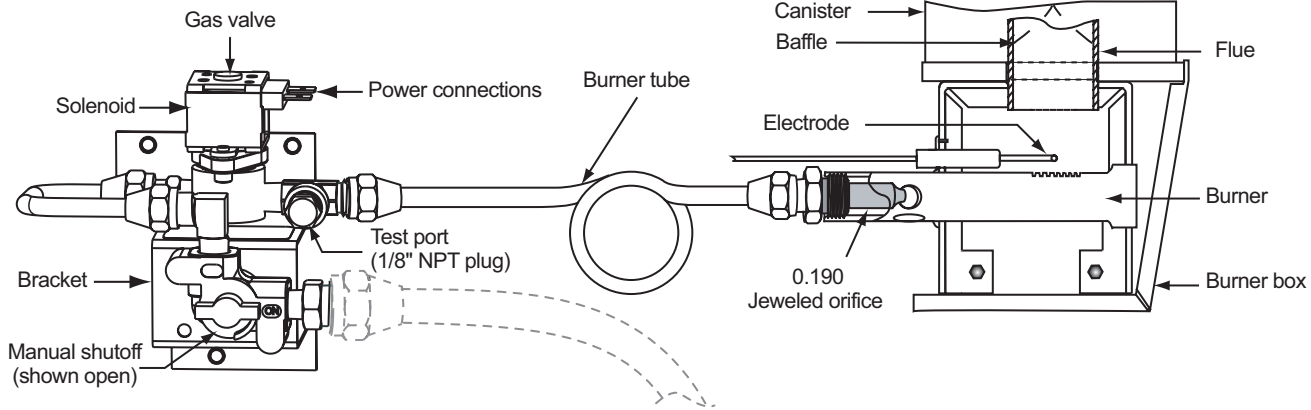

Figure 14. LP gas system, units with S/N 882583 and lower

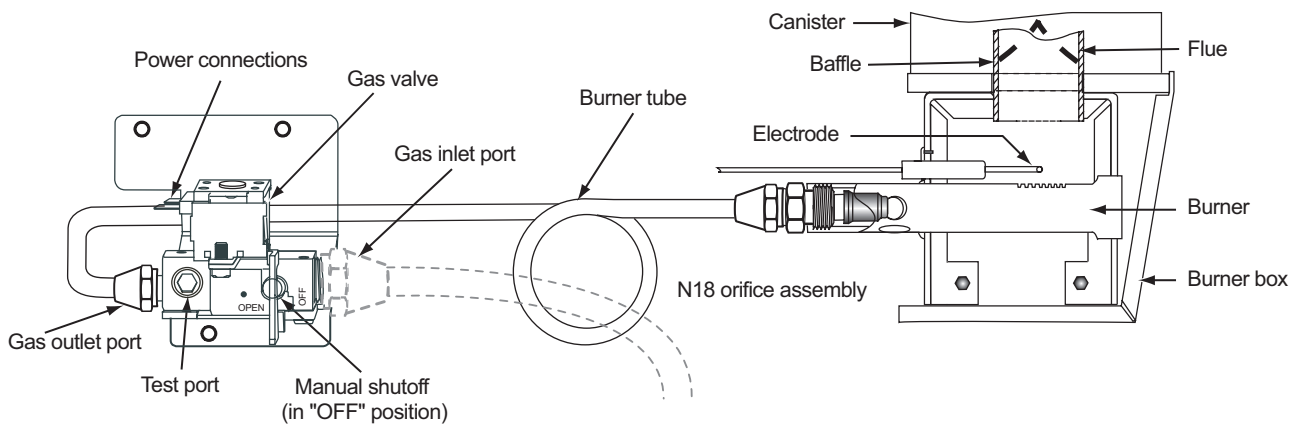

Figure 15. LP gas system, units with S/N 882584 and higher

Pressure Requirements



When working on or near the LP gas system:

- **Do not** smoke or light fires! Extinguish all open flames!
- **Do not** use an open flame to leak test any of the LP gas system components. LP gas is highly flammable and explosive.
- **Do not** connect the refrigerator directly to the LP gas tank. Always use an approved pressure regulator between the LP gas tank and the refrigerator LP gas system.
- To prevent damage to connections, piping, and components, always use two wrenches to tighten or loosen connections. Damaged connections, piping, and components create the potential for gas leaks.

The refrigerator LP gas system, shown in Figure 14, is for propane gas use only. The system working pressure is 10.5 to 11.5 in. water column (in. w. c.). Propane gas pressures below 10.5 in. w.c. or above 11.5 in. w.c. will affect heat output which will directly affect cooling efficiency.

Propane gas flow control is monitored electronically by the control's flame sensing circuit. If the flame sensing circuit does not detect a burner flame within 30 seconds after initiating ignition, power to the gas valve is turned off and gas mode operation is locked out.

Testing for LP Gas Leaks



WARNING

Do not wet or spray liquids on or near electrical connections or electronic components. Many liquids, including leak detection solutions, are electrically conductive and can create an electric shock hazard, short electrical components, and/or damage electronic circuits.



CAUTION

Do not use leak test solutions that contain ammonia or chlorine. Ammonia and chlorine attack copper and brass components.

Leak testing can be accomplished using an electronic leak detector or a commercial grade leak test solution. The use of homemade soap and water leak test solutions should be avoided if possible. When applying a leak test solution, apply the solution over the entire joint using a small brush or spray applicator.

Due to low system operating pressure, it may take a few minutes for bubbles to appear if the connection is leaking. Hidden joints should be examined thoroughly using an inspection mirror.

Components



CAUTION

When working on the refrigerator LP gas system:

- Do not alter or modify the burner tube anti-vibration loop.
- Do not crossthread fittings by taking extreme care disconnecting and connecting fittings.
- Leak test all of the refrigerator propane gas system fittings after servicing, repairing, or replacing components.

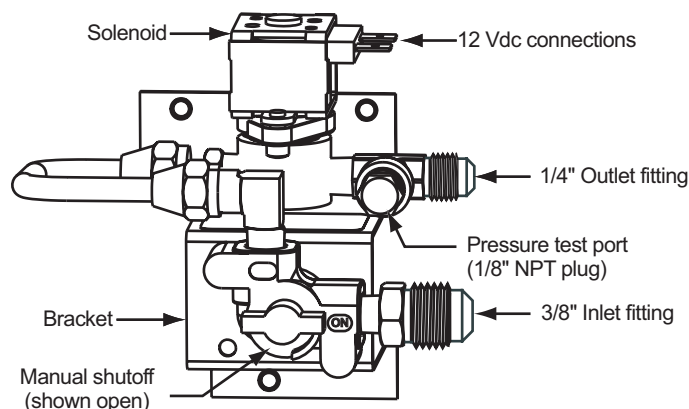

Figure 16. Old style solenoid gas valve (SN<657908)

Gas Valve

The electronic controls automatically open gas valve. The gas valve also has a manual shut-off and capped pressure test port. The shut-off is a spring-loaded, quarter turn manually operated valve. See Figures 16 and 17 for the old style gas valve. See Figures 18 and 19 for the new style gas valve.

To manually shut off gas to the burner, pull the valve's handle slightly away from the body, then turn it one-quarter, turn (90 degrees) counterclockwise.

Units with serial numbers lower than 657908 (manufactured before 02/16/99) are equipped with the old style solenoid gas valve. See Figure 16 and Figure 17.

Units with serial numbers 657908 and higher (manufactured on or after 02/16/99) are equipped with the new style solenoid gas valve. See Figure 18 and Figure 19, page 26.

Solenoid Gas Valve Connections

For both the old and new style valves, the solenoid gas valve inlet fitting is 3/8 inch, with male threads; the outlet fitting is 1/4 inch, with male threads.

Replacing Old Style Gas Valve

Use the NORCOLD gas valve conversion kit part number 62133 to replace the old style gas valve. The kit contains the new style solenoid gas valve, all the required hardware and instructions.

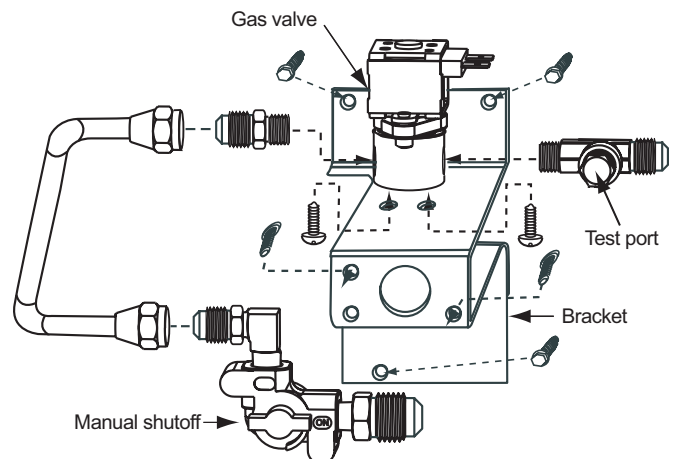

Figure 17. Old style solenoid gas valve components

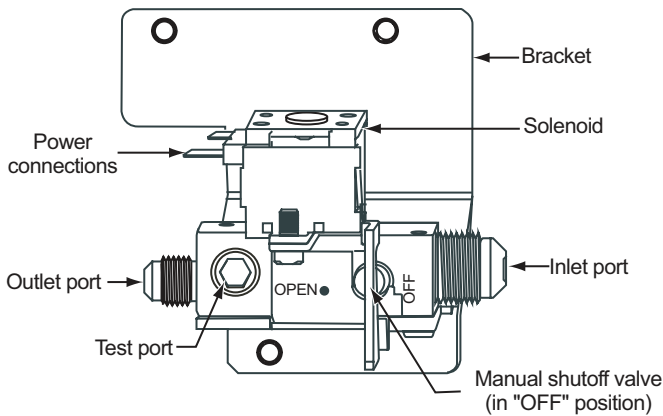

Figure 18. New gas valve (SN>=657908)

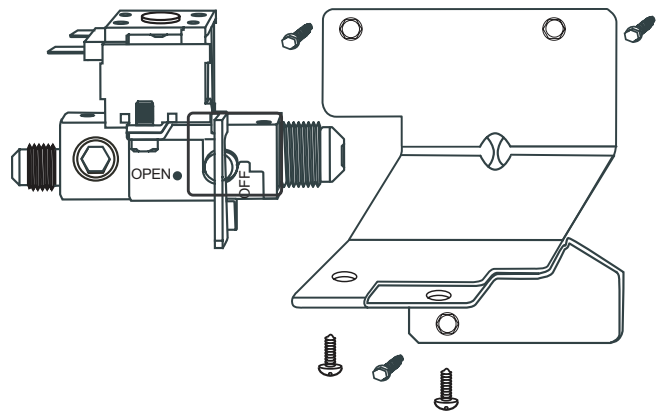

Figure 19. New gas valve components

Burner Tube

The burner tube is 1/4 inch OD aluminum tubing with an anti-vibration loop. Each end of the tube is a double flare. See Figure 20.

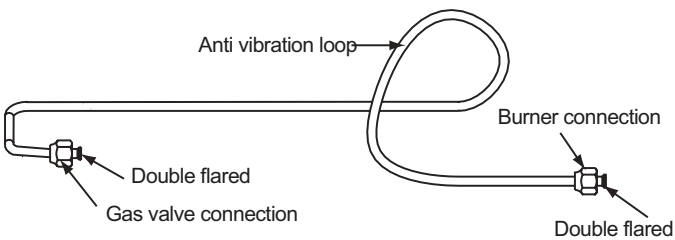

Figure 20. Burner tube

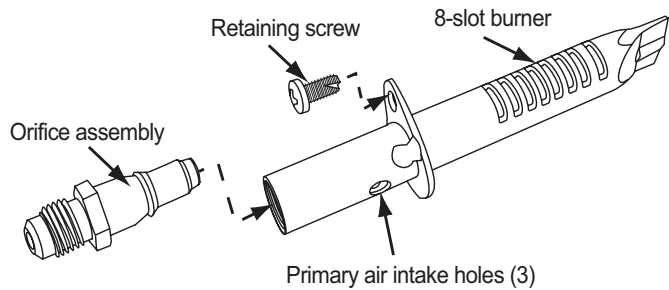

Figure 21. Burner assembly and orifice

Burner

The burner, shown in Figure 21, houses the orifice, provides primary air for combustion, and is the fuel mixing chamber. Primary combustion air flows into the burner through the three primary air intake holes. Blocking any of the three holes will affect combustion. Carbon deposits on the burner slots is the main cause of no cooling or poor cooling performance due to a weak flame lacking the required heat input.

Orifice

! WARNING

Do not separate orifice from its adapter. Separating the assembly breaks the seal and will cause LP gas to leak.

The orifice (see Figure 21) controls the flow of propane gas to the burner. 1200XX/120X-IMXX units with serial numbers 882583 and lower originally were factory equipped with 0.190 jeweled style orifice. See Figure 22. Units serial numbers higher than 882583 were factory equipped with N18 cap style orifice. See Figure 23. Installing a smaller, larger, or damaged orifice will affect combustion.

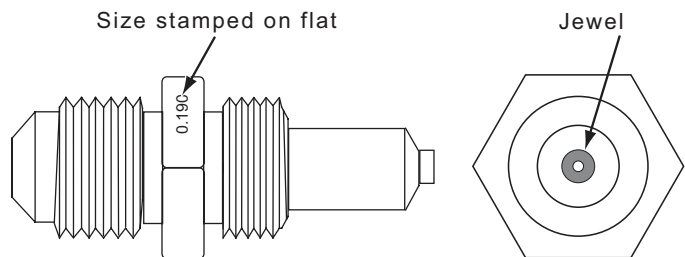

Figure 22. 0.190 jeweled orifice

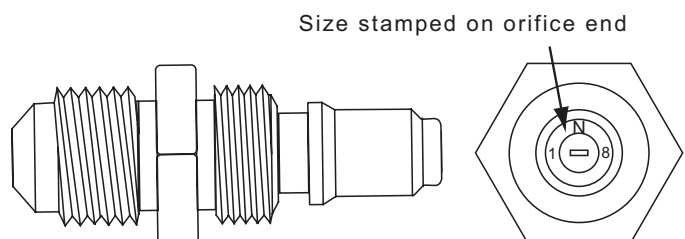

Figure 23. N18 orifice

Flue

The flue comes equipped with a removable baffle and a metal flue cap. The flue cap is shown in Figure 25 insert a. The location of the flue baffle is shown in Figure 25, insert b.

The flue and the condition of the baffle should be checked annually. In roof exhaust venting applications, the refrigerator has to be removed from the enclosure to check or service the flue, flue cap or baffle.

In most sidewall exhaust venting applications, removal of the sidewall exhaust vent provides clear access to service the flue or any of its components.

A one inch diameter, loop-handle, twisted wire brush with a 27 inch wire handle is recommended for sweeping clean the flue.

Flue Cap

The flue cap, see Figure 24, insert a, deflects hot exhaust gases sideways. It also keeps dirt and debris from falling inside the flue. Cooling performance may be affected if the blocks the flue opening.

Flue Baffle

The flue baffle, see Figure 25, transfers heat to the cooling unit generator.

A retaining wire suspends the flue baffle in the flue approximately 3 inches away from the peak of the flame. The condition of the flue baffle should be checked annually. In roof vented installations it is necessary to remove the roof vent assembly or the refrigerator. To check the flue baffle:

1. Remove the flue cap.
2. Unclip the baffle retaining wire from the rim of the flue.
3. Pull the baffle out of the flue tube and check same for excessive corrosion



Do not cut or modify the flue baffle retaining wire!
The wire positions the baffle for optimal heat transfer.

Flame Appearance

The flame should be light blue with sharp blue root cones and a steady burning flame plume. See Figure 26.

A flame that is mostly orange or yellow, is erratic, and/or unstable, indicates a "dirty" burner. See page 28 for burner cleaning procedure.

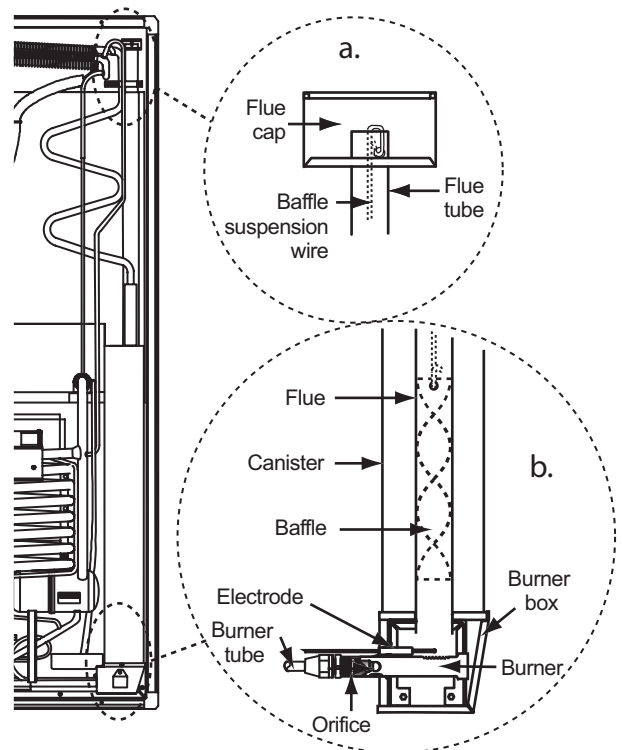

Figure 24. Flue and components

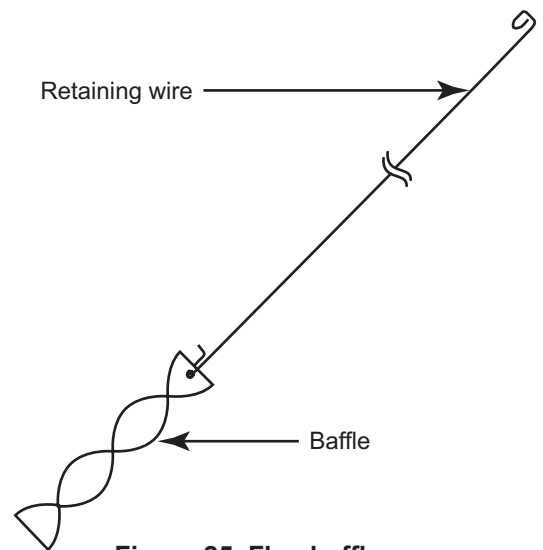

Figure 25. Flue baffle

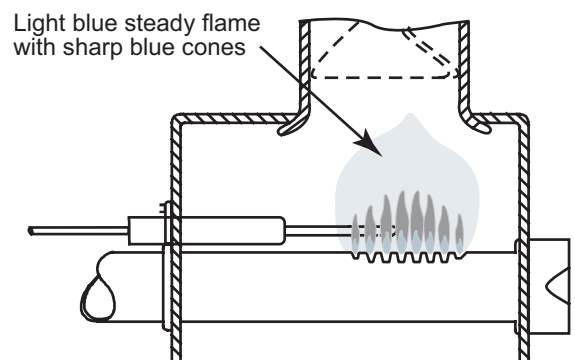

Figure 26. Flame appearance

Burner Cleaning Procedure



Burn hazard! Allow the burner box and burner components to cool before attempting to service the burner assembly or components.

1. Turn OFF power to the refrigerator.
2. Close the LP gas tank valve.

For steps 3 - 5, refer to Figure 34, page 35.

3. Close the combination gas control valve manual shut-off.
4. Remove the drip cup.



To prevent damage to connections, piping, and components, always use two wrenches to loosen the burner tube. A damaged burner tube creates a potential for gas leaks.

5. Remove the burner box cover.

For steps 6 - 8, refer to Figures 14 and 15, page 24.

6. Disconnect the burner tube from the orifice assembly.
7. Remove the orifice assembly from the burner.
8. Remove the burner retaining screw.
9. Remove the burner from the burner box frame.
10. Clean the burner.

NOTE

The burner slots may be cleaned with a small flat file. The inner bore of the burner body may be cleaned with a 3/16 in, double-spiral wire brush. Do not damage the threads when cleaning the inner bore of the burner.



Do not insert any type of cleaning tool or wire into the orifice. Do not drill or ream the orifice opening to clean it. Insertion of any type of cleaning tools, reaming, or drilling through the opening will alter the volume of LP gas flow to the burner and creates a fire hazard potential.

11. Visually inspect the orifice. If dirty, wash the assembly in denatured alcohol, then allow to air dry. If cleaning fails to remove dirt or if the condition of the orifice assembly is questionable, replace the orifice assembly.
12. Clean dirt or debris from the burner box base.
13. Reinstall the burner. Do not overtighten the retaining screw.



To avoid gas leaks and prevent damage to connections, piping, and components, always use two wrenches to tighten the burner tube. A damaged burner tube creates a potential for gas leaks.

14. Install the orifice assembly. Thread the orifice assembly into the burner finger tight, then finish tightening using two wrenches.
15. Connect the burner tube. Thread the fitting finger tight, then finish tightening using two wrenches.
16. Install the burner box cover. Do not overtighten the retaining screw.
17. Open the LP gas tank valve.
18. Open the solenoid gas valve manual shut-off.
19. Turn ON the refrigerator and select the LP Manual Mode operation.
20. Leak test LP gas connections during the 30 second trial-for-ignition.



Do not attempt to repair LP gas leaks with the refrigerator in operation. Before attempting to repair a gas leak:

- Turn OFF the refrigerator.
- Close the LP gas valve and the solenoid gas valve manual shut-off.

DC Voltage Requirements and Polarity

The operating controls require 10.5 to 15.4 Vdc to operate. The positive wire lead (+) connects to power board terminal **12VDC**; the negative wire lead (-) connects to terminal **GND1**.

Power Board DC Fuse



Never replace a fuse with a higher amperage rated fuse. Always use the specified fuse.

The controls circuit fuse is a standard automotive blade type fuse. It is located on the power board, terminal **F1**.

DC Power Wiring Requirements



Never use undersized wires to supply DC power to the power board. Undersized wires may cause wires to overheat and creates an electrical fire hazard.

18 AWG is the minimum AWG size wire that can be used for connecting DC power to 2-way models. The fuse size for overload protection must not exceed 6 amps.

AC/DC Converter as Power Source

The power board must be supplied 12 volt DC only from the filtered output (battery side) of a converter.

Unfiltered voltage (commonly referred to as AC ripple) output of AC/DC converters can cause the electronic controls to set false fault codes. It can also turn off the refrigerator or prevent the refrigerator from turning off.

Lamp/Thermistor Assembly

The operation of the fresh food compartment 12 volt DC lamp is controlled by two switches mounted on the underside of the divider section of the refrigerator. Opening either fresh food compartment door allows the switch to close, which turns on the light.

Leaving the door ajar or open for more than two minutes causes the controls to display a "dr" fault code. Closing the door turns off the light and clears the "dr" fault from the display. The fault code is stored in the diagnostic mode non-volatile memory. For "dr" troubleshooting procedures, see page 15. As shown in Figure 27, the light assembly harness and thermistor share a molded connector.

Older models, S/N 83170 and lower, the thermistor is attached to the 20th fin, counting from right to left from the label side of the cabinet.

On models S/N 832171 and higher or older models equipped with a frost management power board the thermistor is connected to the second fin, counting from right to left from the label side of the cabinet. The thermistor is the temperature sensing circuit sensor. If it fails open or shorted, the controls activate the Backup Operation Mode to keep the refrigerator in operation.

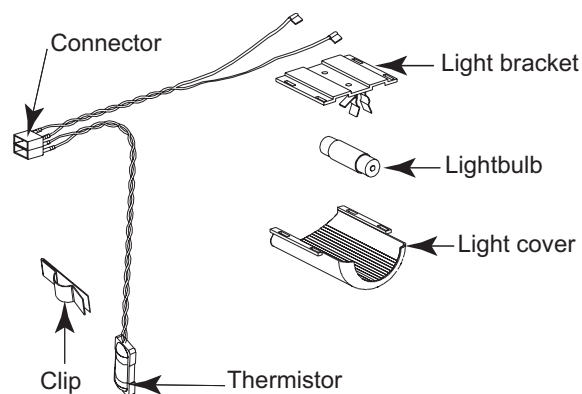

Figure 27. Lamp/thermistor assembly

Divider Heater

The divider heater is permanently "foamed" between the divider separating the freezer and fresh food compartment. The controls constantly monitor power board voltage output to the heater through built in diagnostics (see pages 46 and 50). Turning the refrigerator on automatically send power to the heater.

AC Power Requirements



WARNING

Electric shock hazard! The refrigerator receives power from more than one source. Unplug the AC cord from the RV AC receptacle before servicing electrical or electronic components.

AUTO AC and AC Manual Mode operation require 108 to 132 Vac. AC power must be supplied through a 2 pole/3 wire/20 amp grounding type receptacle.

AC Heaters



WARNING

Do not wire the heater direct! Wiring the heater directly bypasses control safety devices and creates the potential for an electrical fire.

The AC mode uses two AC heaters, see Figure 28. Each heater is rated for 225 watts @ 120 volt AC and has a nominal resistance of 64 Ohms at ambient temperature.

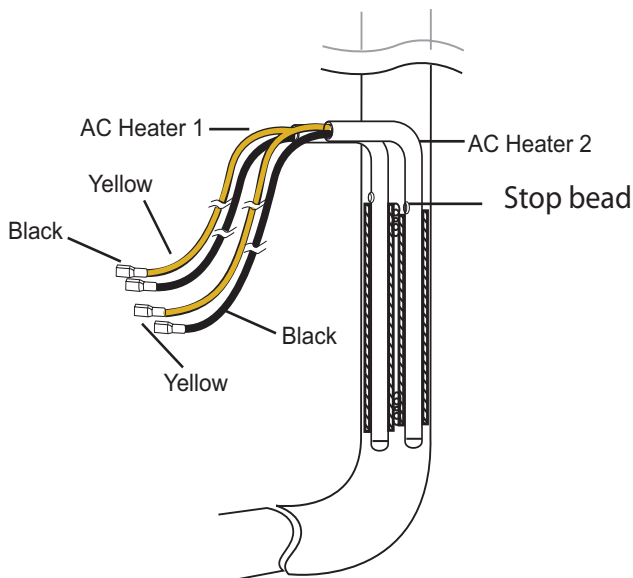

Figure 28. AC heaters

When there is poor or no cooling in AUTO AC or AC Manual Mode:

- Measure AC voltage input to the power board.
- Measure heater amp draw.
- If amp draw is not as specified, measure the heater's resistance at ambient temperature.

NOTE

Heater resistance has to be measured at ambient temperature.

When replacing the AC heater make sure the stop bead rests fully against heater tube rim. Figure 28 shows the location of the stop bead.

AC Heaters Circuit Fuse

The AC circuit fuse is a fast acting 5 amp $\frac{1}{4}$ " x $1\frac{1}{4}$ " AGC type. It is on the power board, terminal F3.

Power Board AC Power Cord



WARNING

The following warning is present on each ac cord and should be strictly followed: This appliance is equipped with a three-prong (grounding) plug for your protection against shock hazards and should be plugged into a properly grounded three-prong receptacle. Do not cut or remove the grounding prong from this plug.

The power board is supplied AC power through a black AC power cord. See Figure 29. Do not modify or cut the cord's grounding prong. Always make sure that ground wire (green wire) is tightly fastened to the refrigerator cabinet metal plate. The rounded side of the AC cord's power board connection must be connected to the power board with the rounded side facing left.

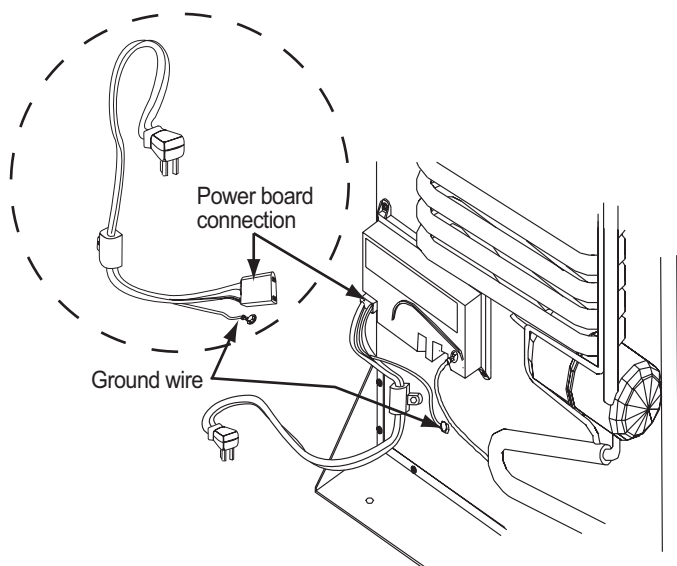

Figure 29. Power board AC power cord

Ice Maker AC Power Cord - Earlier Models

On earlier models, the ice maker power cord and the AC power cord are connected as one unit. Figure 30 shows the AC power cord for earlier models without ice maker (Figure 30 (a)) and the AC power cord for earlier models with ice makers and 1201LRIM refrigerators.

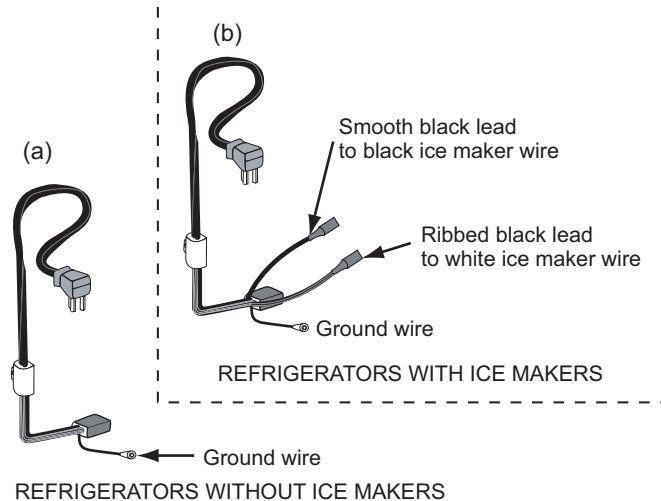

Figure 30. AC power cord on earlier models

Ice Maker AC Power Cord

The ice maker is supplied AC power through the white AC power cord, which is separate from the power board AC cord. The cord and its connections to the ice maker wire harness are shown in Figure 31. The ice maker cord can be detached from the power board AC cord by cutting the two plastic cable ties holding them together.

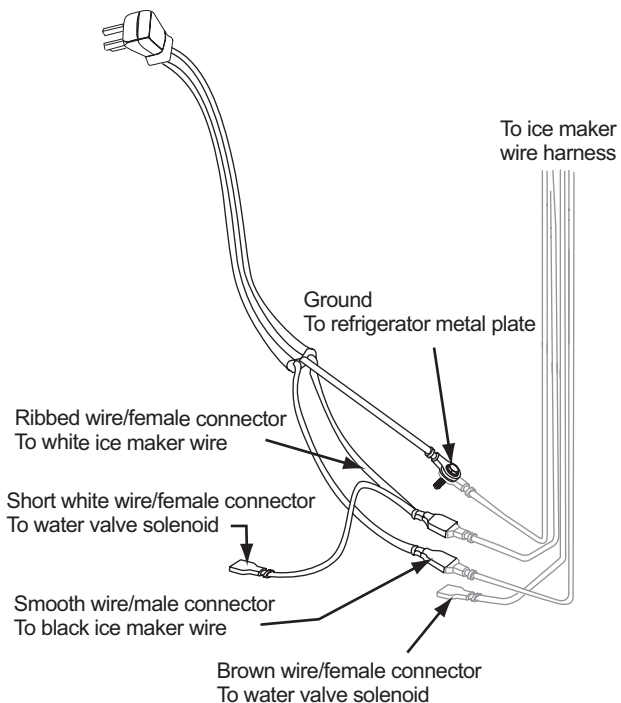

Figure 31. Ice maker power cord

12 volt DC Fans

The two ventilation fans are located on top of the absorber coils on the back of the refrigerator. They are secured to the absorber coils by bracket and mounting screws. See Figure 32. The ventilation fan is supplied 12 volt DC through power board connections. Fan operation is automatically controlled by a thermostatic switch.

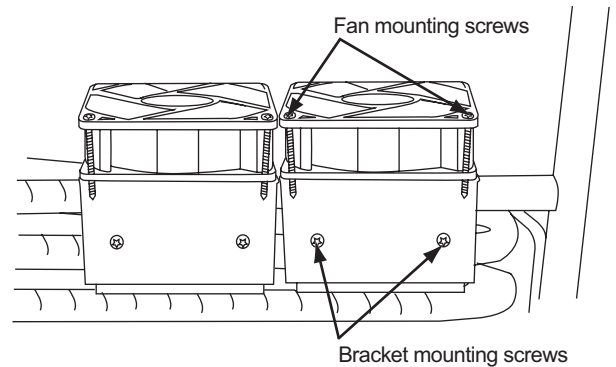

Figure 32. Fans mounted on the top absorber coil

The thermostatic switch is mounted on the condenser fin. See Figure 33. The switch turns the fan on when the temperature is approximately 130 °F. The switch turns the fan off when fin temperature drops to approximately 115 °F.

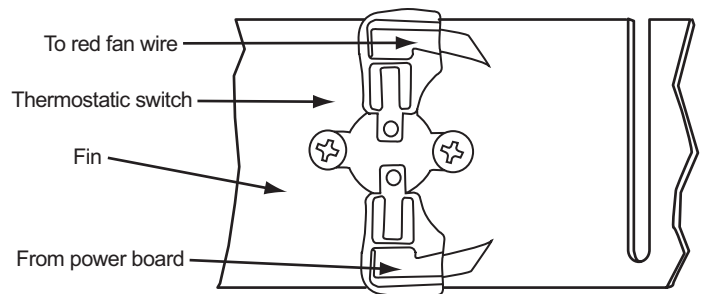

Figure 33. Fan thermostat

- For models with S/N _____ or lower, thermostat will be on first fin from right (boiler side).
- For models with S/N _____ or higher, thermostat will be on first fin from left. When replacing old cooling unit with a new one, be sure to mount the thermostat on the left fin using the holds provided.

COOLING UNIT

Description

The cooling unit is a self-contained gravity flow absorption refrigeration system. The refrigerant charge is a solution of water, ammonia, sodium hydroxide, and sodium chromate (a corrosion inhibitor). Refrigeration is accomplished by applying heat energy and venting the heat extracted from the freezer and fresh food cabinet while maintaining the unit leveled.

Heat Absorption

The refrigerant transfers the heat from the freezer and the food cabinet to the absorber coils. At the absorber coils the metal surface absorbs the heat and air flow over the external surfaces of the coils carries away the heat. A thermal air current is created by the rising hot air and flows out of the enclosure through the roof exhaust vent or sidewall exhaust vent (depending on installation). The flowing air mass passes over the surface of the condenser fins where it absorbs heat transferred from the ammonia vapors flowing through the condenser.

The thermal airflow process creates a "chimney effect." The fresh air drafted by the chimney effect through the intake vent removes rejected heat, supports combustion, and expels the exhaust gases produced by the combustion process. Any obstruction, restriction, or modification to vents or the enclosure will affect the cooling cycle. Poor cooling unit performance may be due to:

- Loose insulation interfering with the ventilation process.
- Construction material or debris left in the enclosure.
- Insect screening covering vents.
- Plastic sheeting covering vents.
- Items stored in the enclosure.
- Modifications to vents or enclosure.
- No roof or sidewall exhaust vent opening.

Information pertaining to ventilation and enclosure requirements appears on page 19 through 23.

Leveled Operation

The circulation of the refrigerant through the cooling unit is accomplished by gravity flow; therefore, the refrigerator must be operated leveled. Off-level operation will effect the flow of the refrigerant through the cooling system. The maximum off-level operation limits are:

- 3 degrees from side-to-side.
- 6 degrees from front-to-back.

Exceeding the maximum off-level limits can permanently damage the cooling unit.

The cooling unit or its performance are not affected when the vehicle is in motion.

Gradual Decrease in Cooling Efficiency

A gradual decrease in cooling efficiency can be caused by the following factors:

- Ventilation obstruction.
- Heat source failure.
- Off-level operation.
- Lack of service or maintenance.
- Inadequate repairs.
- Unauthorized field modifications.
- Cooling unit failure.

Note that a gradual decrease in cooling efficiency is not always an indication of cooling unit failure. If any of these factors exist and are not corrected, a replacement cooling unit will also perform inefficiently or fail.

Step-by-step troubleshooting is the best approach when dealing with a gradual decrease in cooling. It is important to consider that the cooling unit is working, though not efficiently. A Cooling System Diagnostic Flowchart can be found on pages 34 and 35. The cooling unit must reach peak efficiency before troubleshooting can take place. It takes an average of four hours for the refrigerant to reach peak efficiency. This time frame depends on ambient air temperature.

Additionally, ambient air temperature plays a significant role if the unit was not installed correctly. Incorrect installation leads to poor ventilation, which in turn relates to poor cooling performance.

The unit's service and maintenance history should also be considered when checking a cooling unit for poor cooling performance. The service history and the scope of service work performed may lead directly to the cause and resolution of a cooling problem.

Cooling Performance Monitoring Control Units with Serial Numbers 832171 and Higher Only

The Cooling Unit Monitoring Control monitors the fin assembly temperature through the thermistor. This control activates when the refrigerator is turned on or if the fin temperature rises above 50° F (40° F on earlier power board). When the temperature is above 50° F (40° F on earlier power board) and a change in cooling is not detected in a specific amount of time, the refrigeration heat sources are turned off. The Cooling Unit Monitoring Control will not activate if:

- The fin assembly temperature stays below 50° F.
- If the thermistor is disconnected, open, or shorted.
- If the fresh food compartment door is sensed open (resampling starts 10 minutes after the door is closed).
- The AC heater is open.
- AC voltage is sensed low.
- Frost management is active.

Cooling Unit Monitoring Control Operation

The Cooling Unit Monitoring Control operates in the following sequence:

1. Because the fin temperature is above 50° F when the refrigerator is turned ON, sampling begins when the refrigerator is turned ON and stops when the fin temperature falls below 50° F.
2. The Control activates when the fin temperature rises above 50° F with the controls demanding cooling.
3. The Control samples the fin temperature every ten minutes for a period of two hours.
4. If there is no decrease in temperature in this two-hour time period, the Control turns off the active refrigeration heat source.
5. After ten minutes, the Control restarts the heat source and monitors the fin temperature every ten minutes for another 40 minutes.
6. Within this 40-minute time period the temperature must decrease or the Control will turn off the refrigerator and lock out the heat sources.
7. Once the heat sources have been locked out, the optical control assembly displays the "no co" fault code and an audible alarm sounds.

First "no co" Fault Occurrence

The first time the "no co" fault code appears on the optical control assembly, it can be cleared by the user by turning the refrigerator OFF and then back ON. This gives the user the opportunity to check for problems that may have caused a "no co" code, such as obstructed ventilation. This fault code occurrence is then stored in the controls. If the refrigerator completes a full cooling cycle after the user turns it back on, this fault code occurrence will be cleared from the controls.

NOTE

"No co" fault code occurrences are not stored in the built-in diagnostic stored fault history accessible through the Diagnostic Mode. Instead they are stored in a separate, unaccessible stored fault history.

Second "no co" Fault Occurrence

If the refrigerator does not complete a full cooling cycle after the user turns the refrigerator back on and the "no co" fault displays, the control locks the heat sources and a "hardwire" power board reset is required. The hardwire reset of the power board must be performed by a service center according to the procedure on page 18.

Refrigerant Leakage



WARNING

Do not operate the refrigerator if the cooling unit is leaking or leakage is suspected.

Yellow powder or liquid deposits at the rear of the refrigerator or ammonia smell inside the refrigerator indicate refrigerant leakage. Exercise extreme care when handling a leaking or a suspected leaking cooling unit. The cooling system refrigerant solution consists of water, ammonia, sodium hydroxide, and sodium chromate.

Disposal of Cooling Unit



WARNING

Do not, under any circumstances, release any waste or residue directly into sewers or surface waters. If any liquid leaks or spills from the cooling unit, contact the nearest environmental services for guidance.

Dispose of cooling unit according to local, state, and federal guidelines and regulations. Dispose of any liquid waste or residue according to pre-emergency planning and all applicable local, state, and federal regulations.

Cooling System Diagnostic Flowchart

⚠ WARNING

Do not bypass or modify the refrigerator's controls or components to diagnose the cooling system. Do not wire the heater directly. The heater is supplied power through a fused circuit.

⚠ WARNING

Do not operate the refrigerator if the cooling unit is leaking or a leak is suspected.

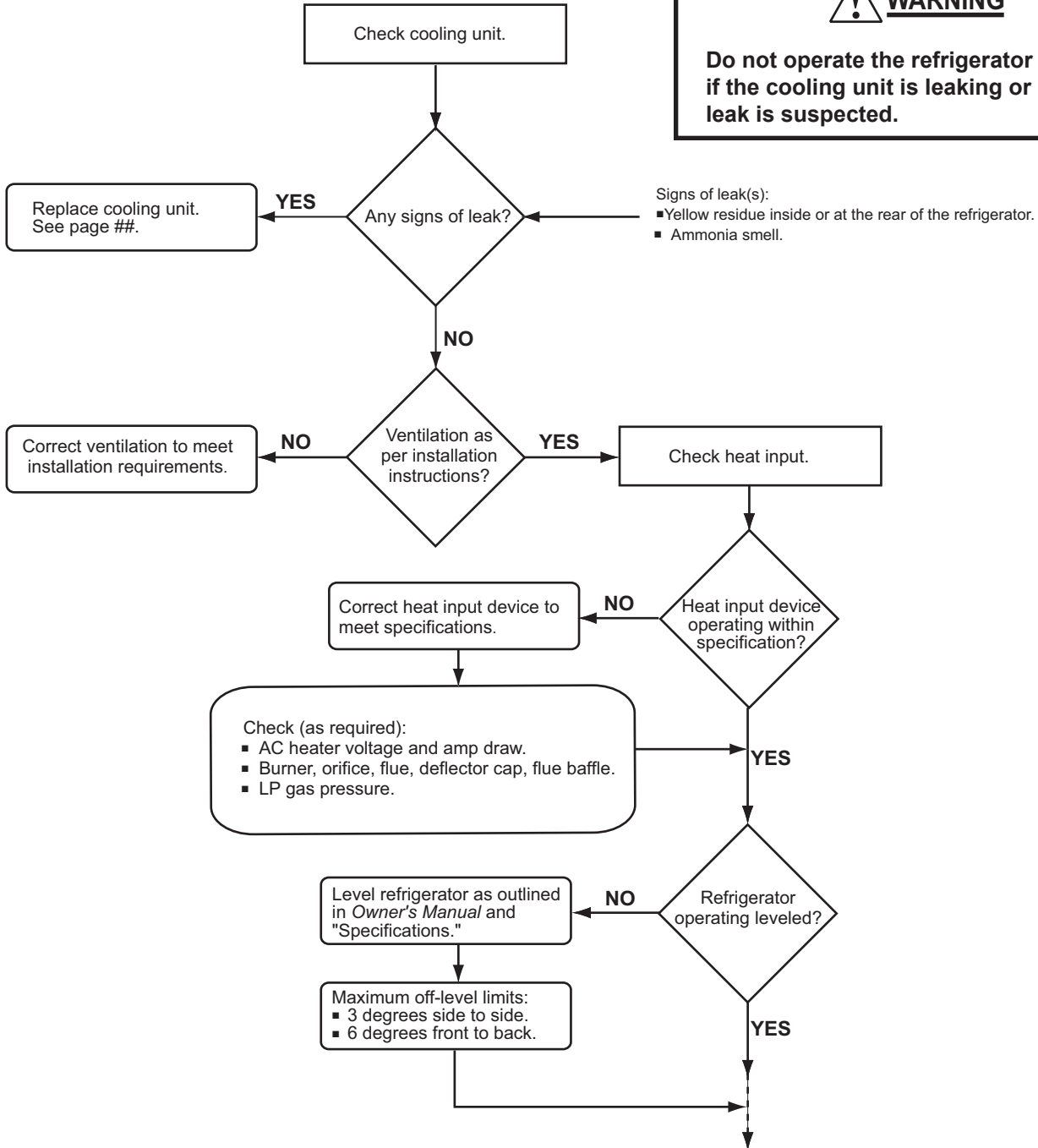

Continued on page 35.

WARNING
 Do not operate the refrigerator if the cooling unit is leaking or a leak is suspected.

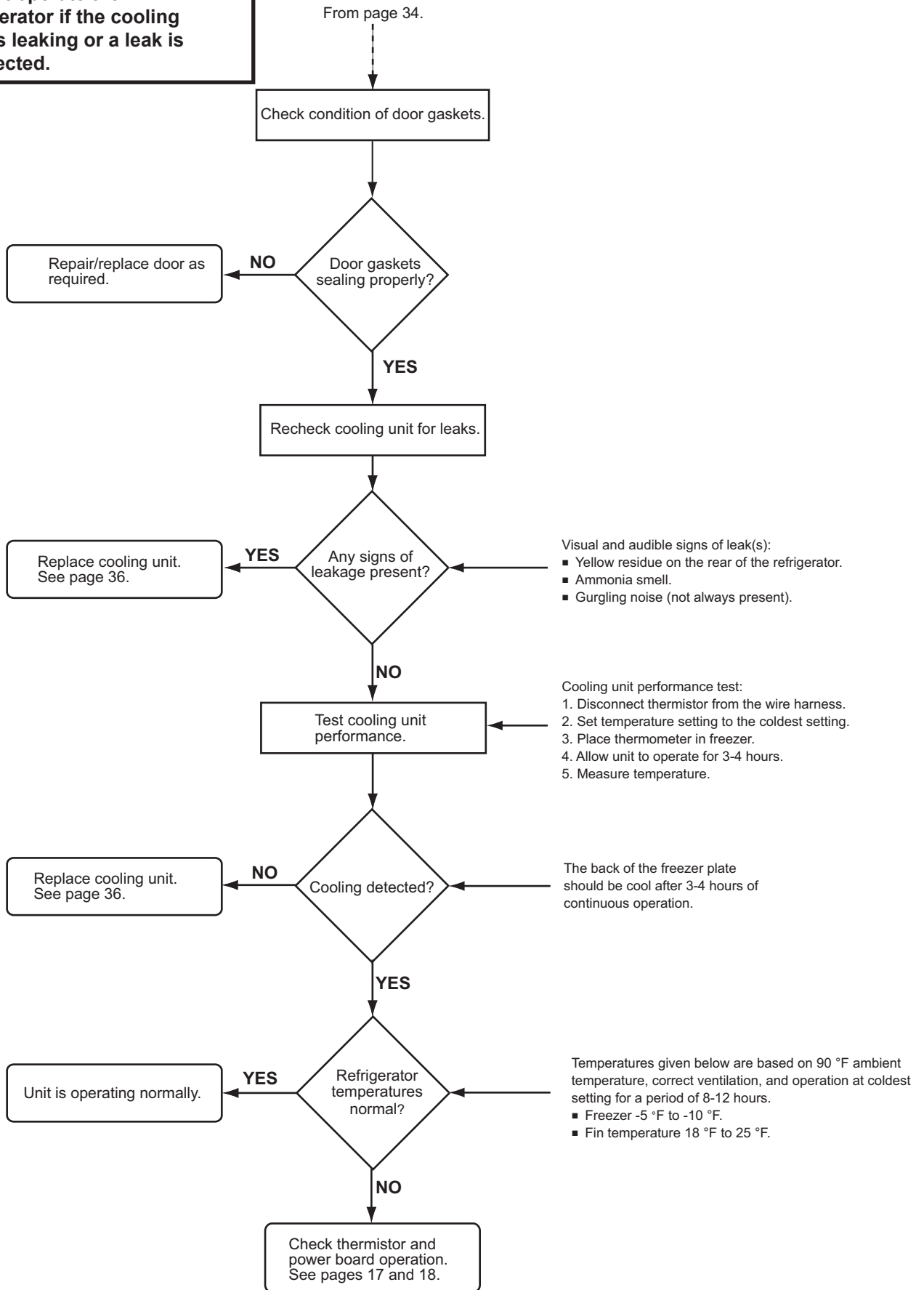

Replacing the Cooling Unit

For models with S/N or higher, fan thermostat mounts to the left-most fin.

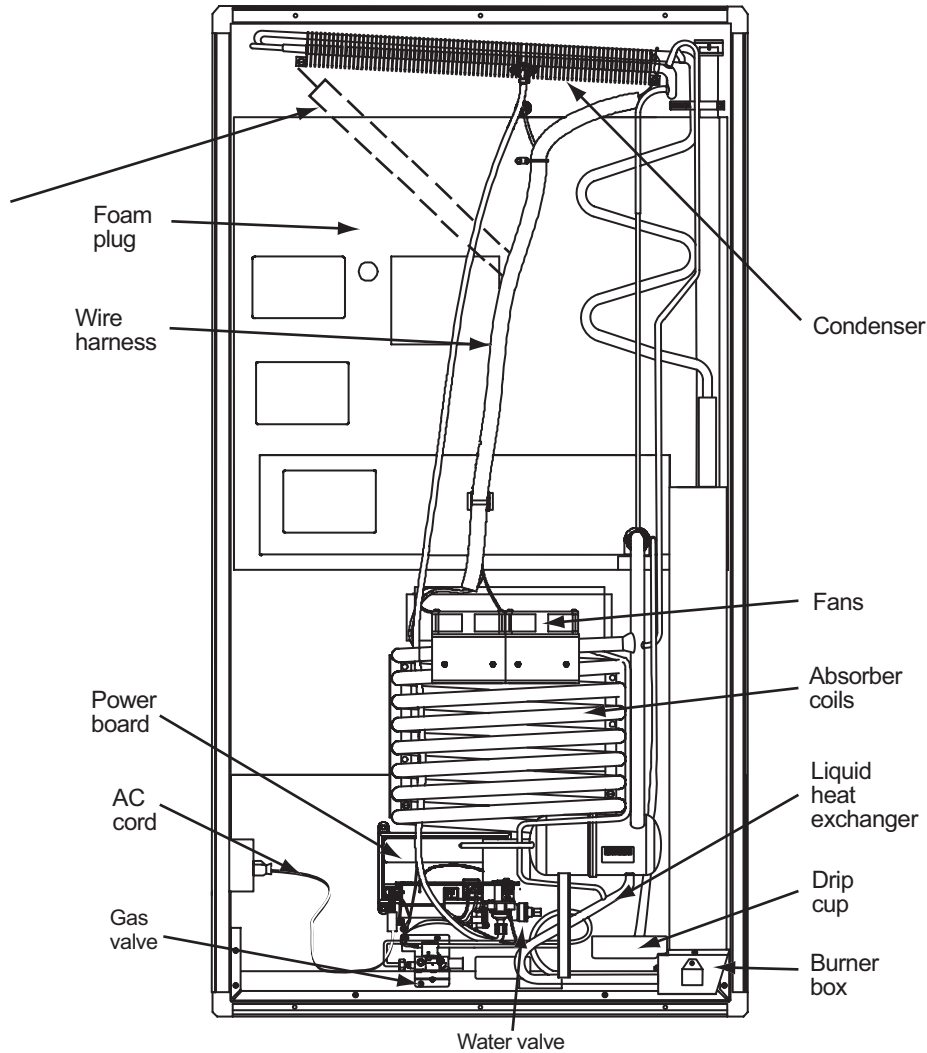

Figure 34. Cooling unit and components
1200IM (ice maker)

NOTE

This procedure supplements the instructions packaged with 1200 model replacement cooling unit. Follow the procedure thoroughly to install the cooling unit correctly. Incorrect installation, adjustments, or modifications will affect cooling performance.

Removing the Refrigerator and Cooling Unit

Refer to Figure 34 to locate components.

1. Turn refrigerator OFF.
2. Close the LP gas tank valve(s).
3. Disconnect 12 volt DC from RV DC distribution panel.
4. Disconnect DC power supply from power board.
5. Unplug AC power cord from RV AC receptacle.
6. Disconnect the RV LP gas supply line from the gas valve.
7. Remove rear mounting flange screws.
8. Remove trim pieces.
9. Remove upper and lower mounting bracket screws.
10. Remove any other mounting screws present in the breaker.
11. Remove the refrigerator from the enclosure.

Removing Cooling Unit

1200IM (ice maker)

- a. Disconnect the ice maker wire harness wires (white and brown wires) from the water valve solenoid.
 - b. Disconnect the ice maker wire harness ground wire.
 - c. Remove the two water valve mounting screws and plastic spacers, then remove the water valve.
1. Remove the fan, bracket assembly, thermostat, and fan wiring from the cooling unit.
 2. Remove the drip cup retaining screw, then remove the drip cup. Remove and save perma gum that seals the drain tube to the back of the cabinet.
 3. Remove the burner box cover retaining screw, then remove the cover.
 4. Disconnect the burner tube from the gas valve.
 5. Remove the burner retaining screw, then remove the burner tube along with the burner.
 6. Disconnect the gas valve wires from the power board.
 7. Remove the gas valve bracket screws (3), then remove the gas valve assembly.
 8. Remove the spark/sense electrode assembly retaining screw, then remove the spark/sense electrode assembly from the burner box.
 9. Remove the burner box retaining screws (2), then remove the burner box.
 10. Disconnect the AC power cord from the power board.
 11. Remove the flapper heater wires.
 12. Remove the power board cover retaining screws (3), then remove the cover.
 13. Disconnect the AC heater wires from power board terminals AC_HT -LO/ AC_HT -LO-1 and AC_HT_HI/AC_HT_HI.
 14. Detach the thermistor from the second evaporator fin.
 15. Cut both the lower and upper cable ties holding the wire harness to the foam plug.
 16. Remove the ice bin and freezer shelves.
 17. Remove the freezer plate retaining screws (eight retaining screws and washers - four in each freezer).
 18. Remove the seven retaining screws from the evaporator fin assembly.
 19. Cut the tape that seals the four edges of the foam plug.
 20. Remove the absorber bracket retaining screws.
 21. Remove the condenser retaining screws. See Figure 35, page 38.
 22. Separate the cooling unit from the refrigerator cabinet. To separate:
 - a. Grab the cooling unit by the liquid heat exchanger.
 - b. Pull cooling unit upward at a slight angle to unseat the foam plug.
 23. Remove the cooling unit from the cabinet.

Installation of Replacement Cooling Unit

For Icemaker and/or dispenser models, also see page 38.

1. Clean the old Mastic sealant from the back of the evaporator plate, fin assembly, and cabinet step.



CAUTION

Use only the NORCOLD approved sealant that is packaged with the new cooling unit. Do not use silicon, latex, or other sealant, which may cause damage to the foam and will greatly reduce cooling efficiency.

NOTE

The sealant must be applied correctly to prevent air from being drawn into the cooling unit's high and low evaporators.

2. Apply a 1/2 inch bead of Mastic sealant to the replacement cooling unit's low and high temperature evaporators, and to the cabinet step. See Figure 36 (a), page 38 (b).
3. Insert the drip tube through the foam block opening.
4. Mate the cooling unit foam plug section to the cabinet step opening. *The foam plug must seat evenly against the cabinet step.*
5. Install the condenser retaining screws. *Do not overtighten the condenser retaining screws.* For icemaker and/or dispenser models, refer to page 38. When installing new system in cabinets made prior to S/N , use only the top two condenser mounting tabs. Check the condenser angle as shown in Figure 35.
6. Install the freezer plate screws to the cooling unit (eight screws with washers). *Do not overtighten the freezer plate screws.*
7. Install the fin assembly retaining screws to the cooling unit (four screws). *Do not overtighten fin screws.*
8. Attach the thermistor to the 2st fin (counting from right).
9. Seal the drain tube opening with permagum.
10. Fasten the absorber brackets of the cooling unit to the cabinet (two screws). *Do not overtighten retaining screws.*
11. Tape all four edges of the foam plug to the cabinet using HVAC metallic tape or heavy duty duct tape.
12. Reinstall the fan bracket, fan, thermostat, and wiring. See wiring diagram on the outer surface of the fan bracket or refer to Figures 42 and 43, pages 45 and 46.
13. Install upper and lower cable ties to wire harness.

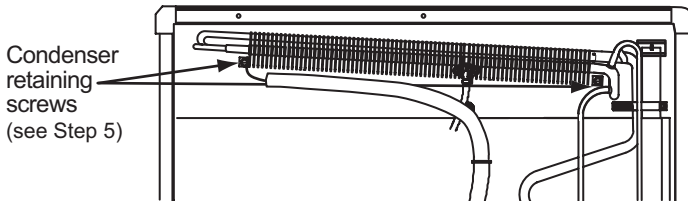
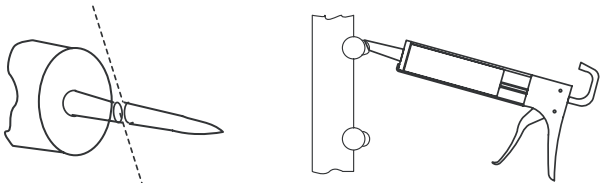

Figure 35. Condenser angle and retaining screw

1200IM (ice maker)

- a. Reinstall the ice maker water valve.
 - b. Reconnect the ice maker water line.
 - c. Connect the brown and the white wires to the water valve solenoid terminals.
14. Install the burner box, then install the burner box retaining screw.
 15. Install the burner tube and burner assembly. *Do not overtighten fittings.*
 16. Install the gas valve and connect the burner tube to the valve. *Do not overtighten fittings.*

17. Install the spark/sense electrode assembly, then install the electrode assembly retaining screw. Set electrode-to-burner air gap 1/8 to 3/16 inch.
18. Install the burner box cover, then install the burner box cover retaining screw.
19. Connect the AC heater wires to power board terminals AC_HT -LO/AC_HT -LO-1 and AC_HT _HI/AC_HT_1.
20. Reinstall the power board cover.
21. Connect the gas valve wires to the power board terminals GV and GV_GND.
22. Connect the flapper heater wires. White wire to FLP/DC_HT and Black to FLP/DC_GND.
23. Plug the AC cord into the power board.
24. Connect the spark/sense electrode assembly to the power board.
25. Attach the fan thermostat to the first condenser fin from the left (as looking at the back) using the screw holes provided.



Cut Thermal Mastic sealant tube to dispense a bead approximately 3/4 inch wide x 1/2 inch thick

Apply a bead approximately 1/2 inch wide x 1/2 inch thick

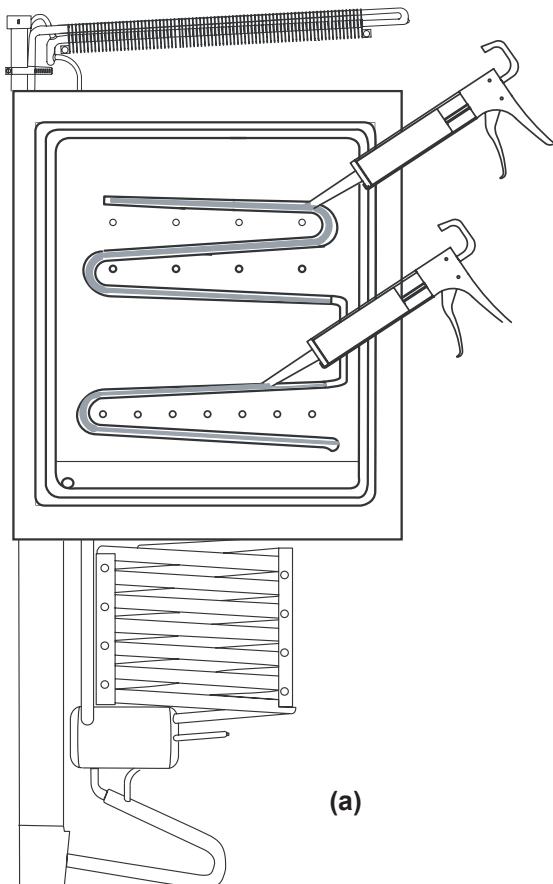

(a)

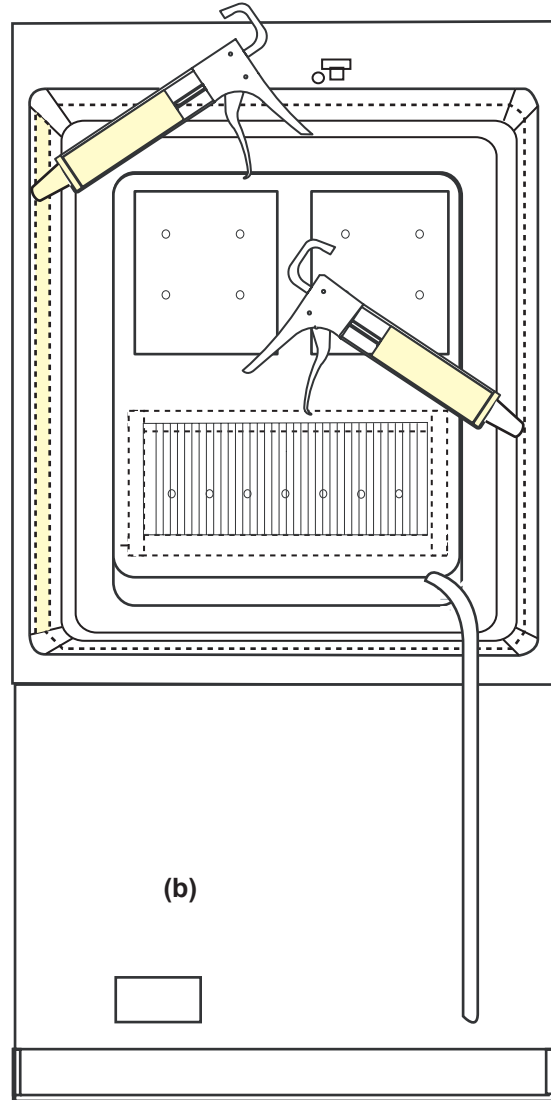

(b)

Figure 36. Application of Mastic sealant on coils and cabinet

Reinstallation of Refrigerator into Enclosure



WARNING

Do not install the refrigerator if the combustion seal has been damaged. A damaged combustion seal must be replaced. The seal isolates the living area of the vehicle from exhaust gases generated by LP gas combustion. LP gas exhaust gases contain carbon monoxide, which is an odorless, colorless gas that can cause dizziness, nausea, or in extreme concentrations, death.

1. Check the condition of the combustion seal. Replace seal if damaged. Do not install the refrigerator if the combustion seal is damaged.
2. Place the refrigerator in the enclosure. The combustion seal must seat fully against the enclosure wall.
3. Install all cabinet retaining screws. See Figures 37 and 38.
4. Reinstall trim pieces. See Figures 45 and 46.
5. Secure the back of the cabinet to the enclosure floor with the mounting flange screws.
6. Install drip cup, then install drip cup retaining screw.

1200IM (ice maker)

- a. Connect the water supply line to the ice maker water valve.
 - b. Open the water supply to the ice maker.
 - c. Check for water leaks.
7. Connect the RV LP gas supply line to the gas valve inlet fitting.
 8. Open the solenoid gas valve manual shut-off.
 9. Plug the refrigerator AC power cord into the RV receptacle.
 10. Connect the RV DC power supply wires to power board terminals 12VDC and 12V_GND1.
 11. Open the LP gas tank valve(s), then leak test LP gas connection at solenoid gas valve.
 12. Leak test the burner solenoid gas valve and orifice assembly burner tube connections.
 13. Place refrigerator in service.

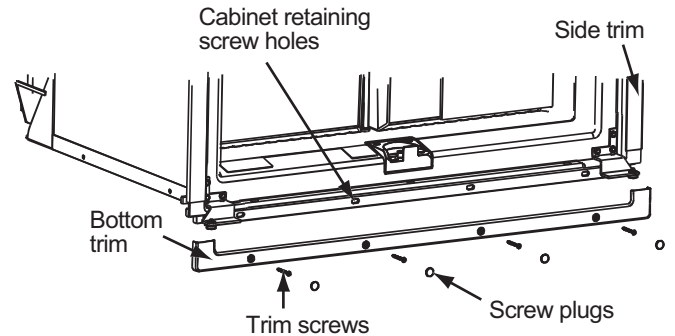

Figure 37. Bottom trim and cabinet retaining screws

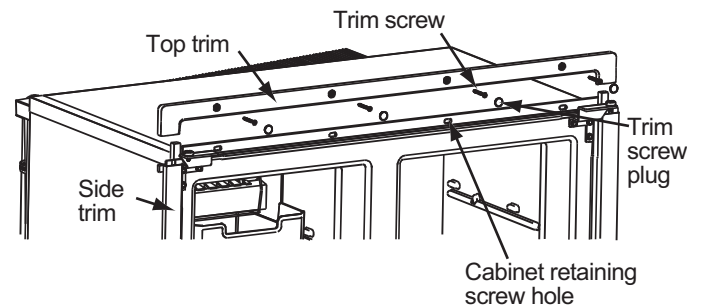

Figure 38. Top trim and cabinet retaining screws

Description

Inputs, outputs, monitoring, and diagnostic functions are managed and controlled by the power board. Inputs, outputs, monitoring information, and diagnostic functions are communicated through the optical control assembly. The wire harness interfacing the power board with the optical control assembly is "foamed" into the cabinet. Wiring pictorials and schematics can be found on pages 52 and 55.

NOTE

Because the wire harness is "foamed" into the cabinet, it is not a replaceable component. This wire harness is not connected to the ice maker wire harness described on page 56.

Power Board

The power board is located on the back of the refrigerator below the absorber coils. It is seated on an insulated base to prevent the printed circuit from making contact with the refrigerator's cabinet metal plate. The power board seated in its base is shown in Figure 47.

Two self-tapping 1/4 inch hex head screws hold the power board and base in place. The power board cover is held by three self-tapping 1/4 inch hex head screws.

Removal—Power Board

1. Turn OFF the refrigerator.
2. Turn OFF the RV DC power to the refrigerator.
3. Disconnect 12 volt DC power from power board terminals 12 VDC and GND1.
4. Unplug the AC power cord from the RV AC receptacle.
5. Disconnect the AC cord from the power board.
6. Disconnect the flapper heater wires from the power board.
7. Disconnect the gas valve wires from power board terminals GV and GV_GND.
8. Disconnect the spark sense electrode wire.

1200IM (ice maker)

- Loosen the water valve bracket, then move the bracket/water valve assembly out of the way.
9. Remove the three 1/4 inch self-tapping hex head screws from the power board cover.
 10. Remove the power board cover.
 11. Disconnect the AC heater wires from power board terminals AC_HI_LO/AC_LO_1 and AC_HI/AC_HI_1.
 12. Disconnect the wire harness connector from power board, terminal P1.
 12. Remove the two 1/4" hex head screws attaching the board to the base, then remove the power board along with its base.

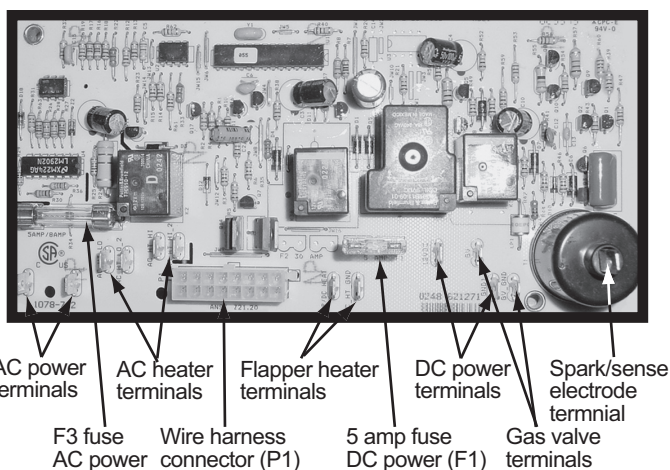

Figure 39. 1200 power board

Installation—Power Board

1. Seat the power board in the base.
2. Attach the power board and base assembly to the refrigerator using two, 1/4 in. self-tapping hex head screws. *Do not overtighten screws.*
3. Connect the wire harness connector to the power board, terminal P1.
4. Connect the AC heater wires to terminals AC_HI_LO/AC_LO_1 and AC_HI/AC_HI_1.
5. Position and align the power board cover over the power board. Attach the cover using three, 1/4 in. self-tapping hex head screws. *Do not overtighten screws.*
6. Connect the solenoid gas valve wires to terminals GV and GV_GND.
7. Connect the spark/sense electrode wire to the power board high tension terminal.
8. Connect the AC power cord to the power board.
9. Connect the fan wires to FLP/DC_HT (White) and FLP/DC_GND (Black).
10. Plug the AC power cord into the RV ac receptacle.
11. Connect 12 volt DC power to the power board.
 - Positive wire (+) to terminal 12VDC.
 - Negative wire (-) to terminal GND1.

1200IM (ice maker)

- Reinstall the water valve and bracket assembly.
12. Turn ON the RV DC power to the refrigerator.
 13. Turn ON refrigerator, then check all power board control functions before placing in service.

TEMP SET Switch

- ▶ Press momentarily to view temperature setting.
- ▶ Press and hold to select a temperature setting.
- ▶ Settings: 1= cold/9= coldest.

Two 7-Segment LED Display

- ▶ Shows operation mode AUTO, AC, and LP.
- ▶ Shows fault codes and diagnostic information.

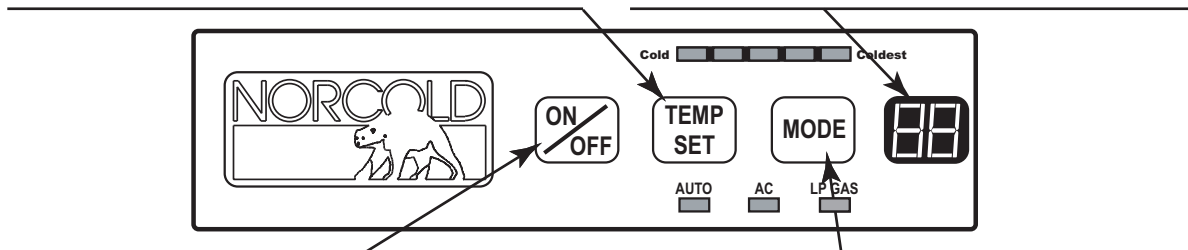

Power Switch

- ▶ Press momentarily to turn ON refrigerator.
- ▶ Press and release after three seconds to turn OFF refrigerator.

MODE Switch

- ▶ Press momentarily to display operating mode.
- ▶ Press and hold to select AUTO, AC or LP Manual Mode.
- ▶ Release when desired mode displays.

Figure 40. Optical control assembly, serial numbers 832170 and lower

TEMP SET Switch

- ▶ Press momentarily to view temperature setting.
- ▶ Press and hold to select a temperature setting.
- ▶ Settings: 1= cold/9= coldest.

Two 7-Segment LED Display

- ▶ Shows operation mode AUTO, AC, and LP.
- ▶ Shows fault codes and diagnostic information.

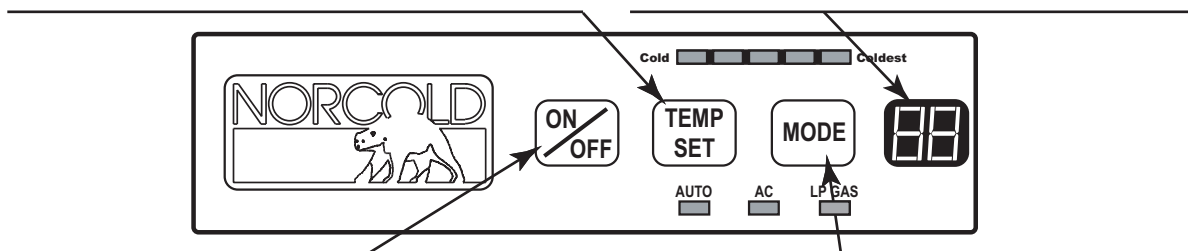

Power Switch

- ▶ Press momentarily to turn ON refrigerator.
- ▶ Press and release after three seconds to turn OFF refrigerator.

MODE Switch

- ▶ Press momentarily to display operating mode.
- ▶ Press and hold to select AUTO, AC or LP Manual Mode.
- ▶ Release when desired mode displays.

Figure 41. Optical control assembly, serial numbers 832171 and higher

Optical Control Display Assembly

The optical control assembly, located on the front of the refrigerator, communicates with the power board through a "foamed in" wire harness (this wire harness is not connected to the ice maker wire harness). Drilling or puncturing the refrigerator rear panels may cause damage to the wire harness. Controls and related features are shown in Figures 48 and 49. Units with serial numbers 832170 and lower have controls shown in Figure 40, and units with serial numbers 832170 and higher have the controls shown in Figure 41. Two screws hold the optical control assembly into place.

Replacing Optical Control Assembly

1. Turn the refrigerator OFF.
2. Remove the two control retaining screws, then remove the front box.
3. Disconnect the optical control assembly from the wire harness.
4. Connect the replacement optical control assembly to the wire harness.
5. Install the optical control assembly on the divider, then install the control retaining screws. *Do not overtighten the retaining screw.*
6. Turn on the refrigerator, then check all of the optical control assembly functions.

Modes of Operation, S/N 832170 and Lower AUTO

In AUTO mode, AC power is the first heat energy source selected by the controls. If AC power is not present, the controls shift to LP gas (propane), the second priority heat energy source.

AUTO AC Operation

When the AUTO mode is selected, the controls:

1. Light AC and AUTO lights while the controls search for AC power.
2. Turn off AC light when AC power is detected. The AU light remains lit. See NOTE 1.

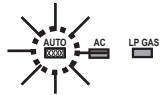

NOTE 1

In AUTO mode, pressing the MODE pushbutton momentarily displays the heat energy source in use.

AUTO LP Operation

The controls shift to AUTO LP mode any time AC power is not available. The controls shift to AUTO LP as follows:

1. AC and AUTO lights are lit while the controls search for AC power.



2. When AC power is not present, the controls shift to AUTO LP mode. The AUTO and LP lights are lit as the controls start a 30 seconds trial-for-ignition.

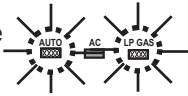

3. Once the controls sense the flame, they turn off the LP light, and display only the AUTO light. See NOTE 1.

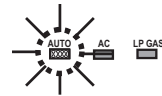

Shift from AUTO LP GAS to AUTO AC

In AUTO mode, the controls shift automatically from AUTO LP GAS to AUTO AC any time the controls sense that AC power is available.

No AC Power and No Flame

When AC power is not present and a flame is not sensed, at the end of the 30 seconds trial-for-ignition, the controls:

1. Shut off power to the solenoid gas valve.
2. Set "gas lock-out." See NOTE 2.
3. Sound the alarm (an intermittent beeping tone).
4. Provide a visual warning by flashing alternating "no" "AC" and "no" "FL" (no flame) fault codes shown below).

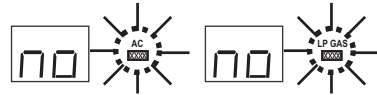

5. Record and store the "no AC" and "no FL" faults in diagnostics nonvolatile memory fault history.

NOTE 2

AUTO LP mode remains in "gas lock-out" until a full cooling cycle on AUTO AC is completed. "Gas lock-out" can also be cleared by turning the refrigerator OFF and back ON.

Troubleshooting No Flame and No AC Faults

Use the following references to identify, troubleshoot, and correct an ignition failure and/or "no AC" faults.

- Page 10, "no FL/no LP" fault codes troubleshooting flowchart.
- Page 13, "no AC" fault codes troubleshooting flowchart.
- Page 47, Diagnostic Mode, Screen 3.
- Page 50, Diagnostic Mode, Screen 4.

AC Manual Mode

In the AC Manual mode, AC power is the only heat energy source selected by the controls. When AC Manual Mode is selected:

1. The AC light flashes as the controls search for AC power.



2. When AC power is detected, the AC light stops flashing and remains lit.



LP Manual Mode

In the LP Manual Mode, LP gas is the only heat energy source selected by the controls. When the controls shift to LP Manual mode:

1. The LP light flashes as the controls start the 30 second trial-for-ignition.



2. Sense the burner flame, the LP light stops flashing and remains lit.



No AC Power Present or Loss of AC Power

If the controls do not sense the presence of AC power or when AC power is lost in AC Manual mode, the controls:

1. Display the "no AC" fault code.

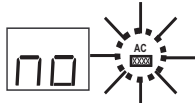

2. Sound the audible alarm. The alarm is an intermittent beeping tone. Pressing the MODE pushbutton silences the alarm.
3. Record and store the "no AC" fault in diagnostics nonvolatile memory fault history.

AC Power Restored

When AC power is restored, the controls:

1. Automatically restore AC Manual Mode operation; however, the recorded fault history will not and can not be erased from memory.
2. Silence the alarm and clear then "no" "AC" fault code from the display.

Troubleshooting "no AC" Fault

Use the following references to identify, troubleshoot, and correct a no AC fault.

- Page 13, "no" "AC" fault codes troubleshooting flowchart.
- Page 47, Diagnostic Mode, Screen 6.
- Pages 50 and 51, Diagnostic Mode, Screens 5 and 8.

If the Propane Fails Ignite a Flame to Reignite

If the propane gas does not ignite a flame or does not reignite a flame within the 30 second-trial-for ignition, the controls:

1. Shut off power to the solenoid gas valve.
2. Set "gas lock-out." See NOTE 3 below.
3. Sound an audible alarm. The alarm is an intermittent beeping tone. Pressing the MODE pushbutton silences the alarm.
4. Display a flashing visual warning, "no" "LP" as shown below.

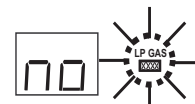

NOTE 5

The LP mode remains in "gas lock-out" until the operation mode is changed or the refrigerator is turned OFF then back ON.

Modes of Operation, S/N 832171 and Higher AUTO

In AUTO mode, AC power is the first heat energy source selected by the controls. If AC power is not present, the controls shift to LP gas (propane), the second priority heat energy source.

AUTO AC Operation

When the AUTO mode is selected, the controls:

1. Display AUTO ("AU") mode operation indicator.



2. Flash "AU" and "AC" as the search for AC power begins.

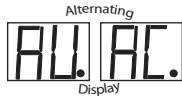

3. Turn off "AU" and "AC" when ac power is detected and only the "ON" LED displays. See NOTE 4.



NOTE 4

In AUTO mode, pressing the MODE pushbutton momentarily displays the heat energy source in use. For example, in AUTO AC, the display flashes **AU** and **AC** alternatively for approximately 10 seconds.

AUTO LP Operation

In the AUTO the controls shift to LP when AC power is not available. The shift is as follows:

1. The AUTO mode operation indicator ("AU") displays.



2. "AU" and "AC" indicator alternate flashing on the display while the controls search for AC power.

3. If AC power is not present, the controls shift to LP mode. "AU" and "LP" flash alternately on the display as the controls start the 30 seconds trial-for-ignition.

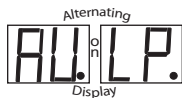

4. Once the controls sense the flame, the "AU" and "LP". The ON LED remains lit.



Shift from AUTO LP GAS to AUTO AC

In AUTO mode, the controls shift automatically from AUTO LP GAS to AUTO AC any time the controls sense AC power is not present at the power board.

No AC Power and No Flame

When AC power is not present and propane fails to ignite a flame at the end of the 30 seconds trial-for-ignition, the controls:

1. Shut off power to the solenoid gas valve.
2. Set "gas lock-out." See NOTE 5.
3. Sound the alarm (an intermittent beeping tone).
4. Provide a visual warning by flashing alternating "no AC" and "no FL" (no flame) fault codes shown below).



5. Record and store the "no" "AC" and "no" "FL" faults in diagnostics nonvolatile memory fault history.

NOTE 5

AUTO LP mode remains in "gas lock-out" until a full cooling cycle on AUTO AC is completed. "Gas lock-out" can also be cleared by turning the refrigerator OFF then back ON.

Troubleshooting No Flame and No AC Faults

Use the following references to identify, troubleshoot, and correct an ignition failure and/or "no AC" faults.

- Page 10, "no" "FL" fault code troubleshooting flowchart.
- Page 13, "no" "AC" fault code troubleshooting flowchart.
- Page 47, Diagnostic Mode, Screen 3.
- Page 50, Diagnostic Mode, Screen 4.

AC Manual Mode

In the AC Manual mode, AC power is the only heat energy source selected by the controls. When AC Manual Mode is selected:

1. The AC mode indicator ("AC") displays as the controls start the search for AC power.
2. When AC power is detected, the AC indicator turns off. The "ON" LED displays. See NOTE 3.



NOTE 6

Pressing the MODE pushbutton displays the "AC" mode indicator.

No AC Power or Loss of AC Power

If the controls do not sense the presence of AC power or when AC power is lost in AC Manual mode, the controls:

1. Display the "no AC" fault code.

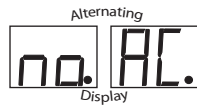

2. Sound the audible alarm. The alarm is an intermittent beeping tone. Pressing the MODE pushbutton silences the alarm.
3. Record and store the "no AC" fault in diagnostics nonvolatile memory fault history.

AC Power Restored

When AC power is restored, the controls:

1. Automatically restore AC Manual Mode operation; however, the recorded fault history will not be erased from memory.
2. Silence the alarm and clear then "no AC" fault code from the display.

Troubleshooting "no AC" Fault

Use the following references to identify, troubleshoot, and correct a "no AC" fault.

- Page 12, "no AC" fault codes troubleshooting flowchart.
- Page 46, Diagnostic Mode, Screen 3.
Page 49, Diagnostic Mode, Screen 4.

LP Manual Mode

In the LP Manual Mode, LP gas is the only heat energy source selected by the controls. When the controls shift to LP Manual mode:

1. The LP mode indicator ("LP") displays and the controls start a 30 second trial-for-ignition.
2. The LP mode indicator turns off when the controls sense a flame. The "ON" LED displays. See NOTE 9.



NOTE 9

Pressing the MODE pushbutton displays the "LP" mode indicator.

Flame Fails to Ignite or Flame Goes Out

If the controls do not sense a flame within the 30 second trial-for-ignition or the flame goes out, the controls:

1. Shut off power to the solenoid gas valve.
2. Set "gas lock-out." See NOTE 10 below.
3. Display a flashing visual warning, "no FL" (shown below).
4. Sound an audible alarm. The alarm is an intermittent beeping tone. Pressing the MODE pushbutton silences the alarm.

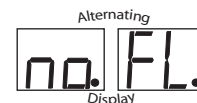

NOTE 10

AUTO LP mode remains in "gas lock-out" until a full cooling cycle on AUTO AC is completed. "Gas lock-out" can also be cleared by turning the refrigerator OFF then back ON.

DIAGNOSTIC MODE - S/N 832170 AND LOWER

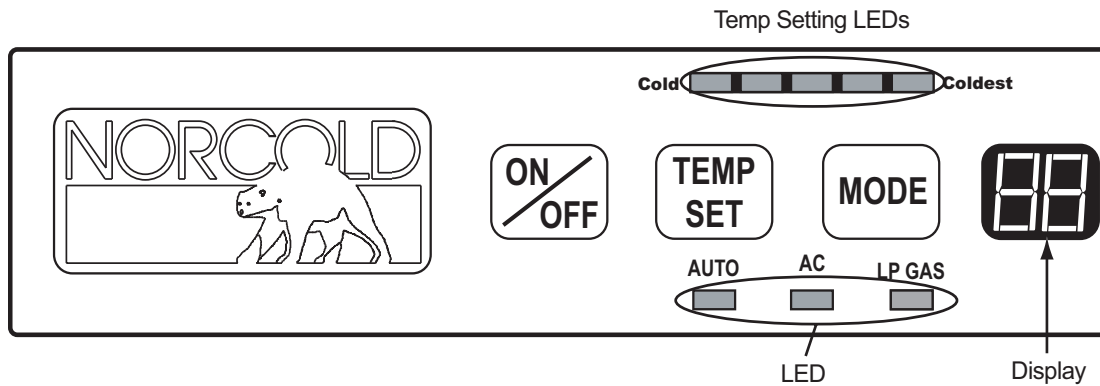

Figure 42. Optical control assembly on units serial numbers 832170 and lower





Diagnostic Mode

The Diagnostic Mode uses ten diagnostic channels, commonly known as "screens," to display "live" inputs, outputs, and fault history. Each screen is numbered. The "screens" for units with serial numbers 832170 and lower incorporates both the LED screen numbers and light emitting diodes (LED). See Figure 50.

This optical control display uses a two 7-segment LED modules LEDs to display the screen number and diagnostic information. Fault history, "live" inputs, and outputs are presented through lit LED segments and the display LEDs (AUTO, AC, LP or temperature setting LEDs).

Accessing the Diagnostic Mode

To access the Diagnostic Mode:





1. **Press and hold both** the  and  buttons **at the same time.**
2. **Release** the  and  buttons as soon as  displays.

Changing Screens

To change screens, **press and hold** the  button until the next screen displays.

Exiting the Diagnostic Mode

To exit the Diagnostic Mode:

1. **Press and hold**  and  buttons **at the same time.**
2. **Release** the  and  buttons when the controls leave the diagnostic mode.

Turning the refrigerator OFF then back ON also exits the Diagnostic Mode.

Screens and Diagnostic LEDS Information, Units with S/N 832170 and Lower

Screen 1, LED Segments Reliability Check

Screen 1 confirms that the LED screen and LED lights are operational. All LED segments and LED lights should light. See illustration.

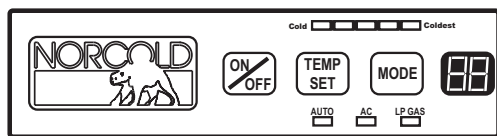

If the screen segments or lights do not match the ones shown in the illustration, the fault is in the optical control assembly. Replacing the optical control should resolve the fault. See page 40.

Press the **MODE** button to bring up screen 2.

Screen 2, LED Segments Reliability Check

Screen 2 diagnostics continue to confirm the reliability of the display. The numerical LED segments and the LED lights turn off. See illustration.

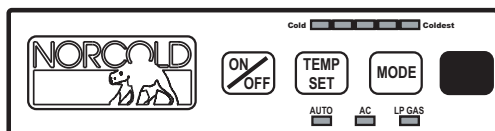

If any of the LED screen segments or LED lights display, the fault is in the optical control assembly. Replacing the optical control should resolve the fault. See page 40.

Press the **MODE** button to bring up screen 3.

Screen 3, Inputs and Outputs

Screen 3 displays the real time activity of the refrigerator.

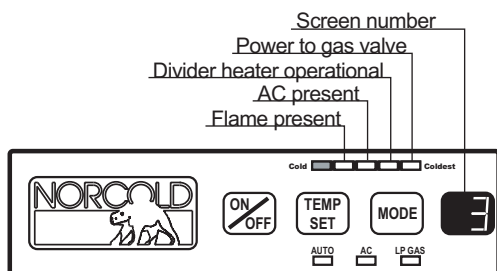

Press the **MODE** button to bring up screen 4.

Screen 4, Input and Outputs

Screen 4 displays the real time activity of the refrigerator.

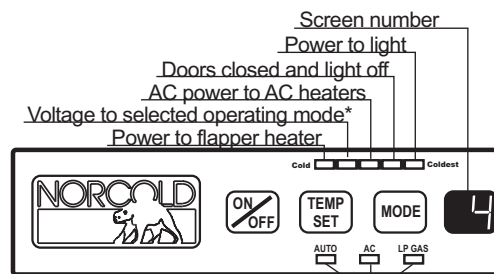

* Selected operating mode displayed on the mode lights

Press the **MODE** button to bring up screen 5.

Screen 5, Stored Fault History

Screen 5 displays stored fault history using LED lights. If a fault occurred, its assigned fault history LED will be on.

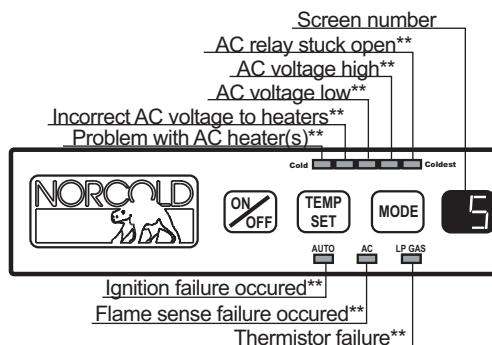

**Lighted LEDs on this screen indicate a previous failure.

Press the **MODE** button to bring up screen 6.

Screen 6, Stored Fault History

Screen 5 displays stored fault history using LED lights. If a fault occurred, its assigned fault history LED will be on.

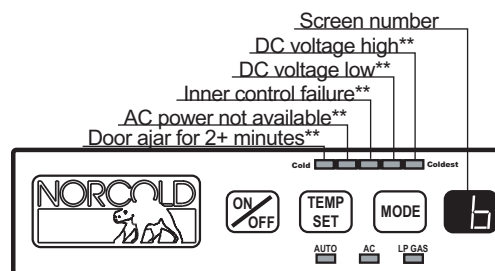

**Lighted LEDs on this screen indicate a previous failure.

Press the **MODE** button to bring up screen 7.

Screen 7, Fin Temperature

Screen 7 displays the actual fin temperature being sensed by the thermistor. **This is not the fresh food cabinet air temperature.** The illustration shows 32°F fin temperature as displayed in screen 7.

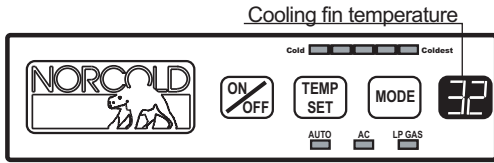

Press the **MODE** button to bring up screen 8.

Screen 8, AC Input Voltage

Screen 8 displays AC input voltage measured by the controls.

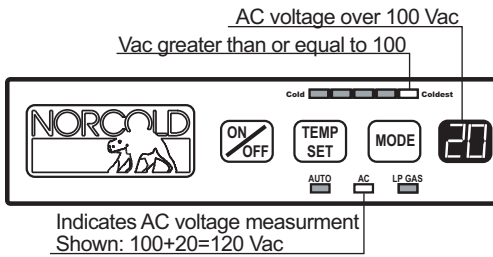

Press the **MODE** button to bring up screen 9.

Screen 9, AC Heater Current

Screen 9 the AC heater current measured by the controls.

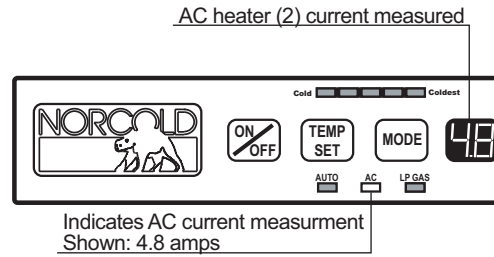

Press the **MODE** button to bring up screen 0.

Screen 0, DC Input Voltage

Screen 0 displays the DC voltage measured by the controls.

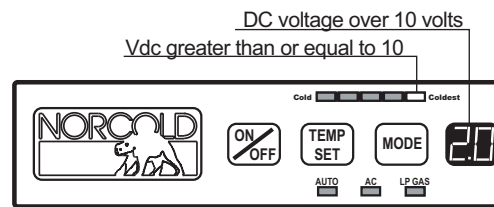

Press the **MODE** button to return to screen 1.

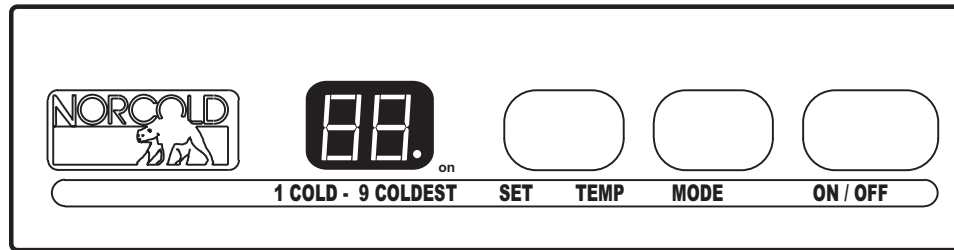

Figure 43. Optical control assembly, units serial numbers 832171 and higher

Diagnostic Mode

The Diagnostic Mode uses ten diagnostic channels, commonly known as "screens," to display "live" inputs, outputs, and fault history. Each screen is numbered. The screen number is always displayed on the left side of the optical control assembly display. See Figures 43 and 44.

This optical control display uses two 7-segment LED module to display the screen number and diagnostic information. Information displayed is made up of four letters or digits that flash in an alternating sequence. Fault history, "live" inputs, and outputs are presented using the LED segments. The fault history LED segments, if present, display on the right of the screen. Diagnostic LED segments numerical identification is shown in Figure 44.

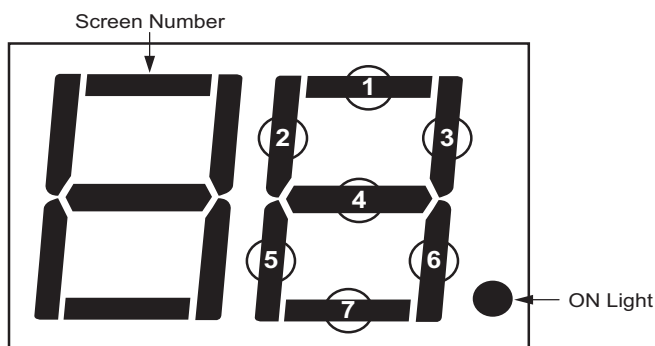









Figure 52. Diagnostic LEDs segments identification.

Accessing the Diagnostic Mode

To access the Diagnostic Mode:





1. Press and hold both the  and  buttons at the same time.
2. Release the  and  buttons as soon as screen  displays.
3. A few seconds later,  displays.

Changing Screens

To change screens, press and hold the  button until the next screen displays.

Exiting the Diagnostic Mode

To exit the Diagnostic Mode:

1. Press and hold  and  buttons at the same time.
2. Release the  and  buttons as soon as the display shows .

Turning the refrigerator OFF then back ON also exits the Diagnostic Mode.

Screens and Diagnostic Segments Information

Screen 1 Diagnostic Mode Active

Screen 1 confirms that the Diagnostic Mode is active. A few seconds after the screen number appears, all LED segments light. See illustration.

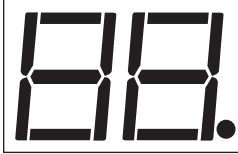

If the screen segments do not match the ones shown in the illustration, the fault is in the optical control assembly. Replacing the optical control should resolve the fault. See page 39.

Press the  button to bring up screen 2.

Screen 2 LED Segments Reliability Check

Screen 2 diagnostics continue to confirm the reliability of the display. After a few seconds only the ON light displays. All other LED segments should be off. See illustration.

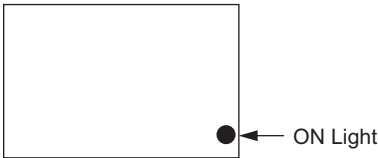

The ON light should be the only LED displayed. If any other LED displays, the fault is in the optical control assembly. Replacing the optical control should resolve the fault. See page 40.

Press the  button to bring up screen 3.

Screen 3 Thermistor Fin Temperature

Screen 3 displays the actual fin temperature being sensed by the thermistor. **This is not the fresh food cabinet air temperature.** The illustration shows 32°F fin temperature as displayed in screen 3.



Screen 4 Stored Fault History

Screen 4 displays stored fault history using lighted LED segments. The illustration provides fault history information with assigned LED segments. **If a fault occurred, its assigned fault history LED will be on.**

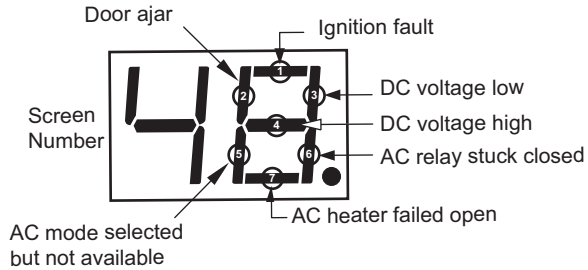

Press the  button to bring up screen 5.

Screen 5 Stored Fault History



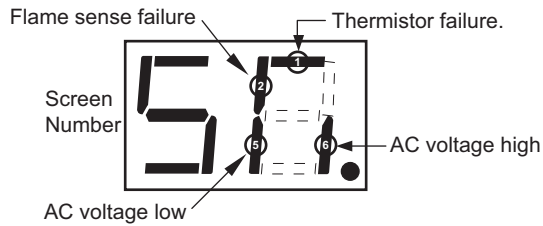



Screen 5 also displays stored fault history using lighted LED segments. The illustration provides fault history information with assigned LED segments. **If a fault occurred, its assigned fault history LED will be on.**



Press the  button to bring up screen 6.

Screen 6 Erase Fault History

Screen 6 provides a way to erase fault history from memory. To erase fault history:

1. Press and hold the  button when  shows on the screen.
2. Release the  button when  shows on the screen.
3. Wait five seconds, then press and hold the  button until  shows on the screen.

Press the  button to bring up screen 7.

Screen 7 Power Board Inputs

Screen 7 displays "live" power board inputs using lighted LED segments. The illustration below provides "live" inputs information and assigned LED segments. **If a power board input is active or "live," its assigned input LED will be on.**

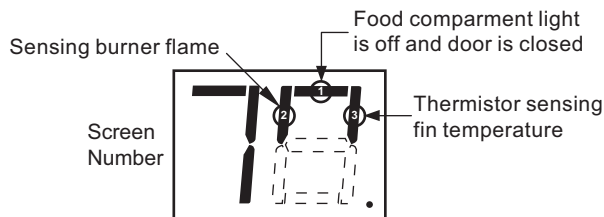

Press the  button to bring up screen 8.

Screen 8 Power Board Outputs

Screen 8 displays "live" power board outputs using lighted LED segments. The illustration below provides "live" outputs information and assigned LED segments. **If a power board output is active or "live," its assigned output LED will be on.**

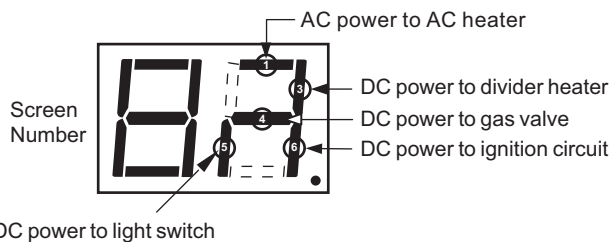

Press the  button to bring up screen 9.

Screen 9 Power Board DC Voltage Status

Screen 9 displays DC voltage status using lighted LED segments. The illustration below provides DC voltage status information and assigned LED segments. **If DC voltage at the power board is within normal range (10.5 to 15.4 Vdc), LED segment 4 will be on.**

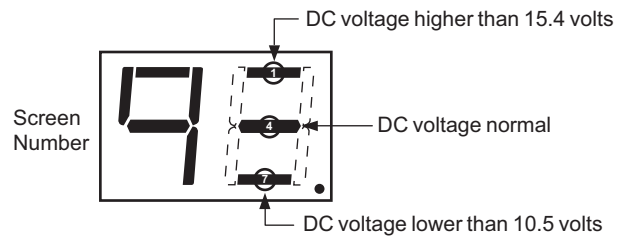

Press the  button to bring up screen 0.

Screen 0 Power Board AC Voltage Status

Screen 0 displays AC voltage status using lighted LED segments. The illustration below provides AC voltage status information and assigned LED segments. **If AC voltage at the power board is within normal range (108 to 132 Vac), LED segment 4 will be on.**

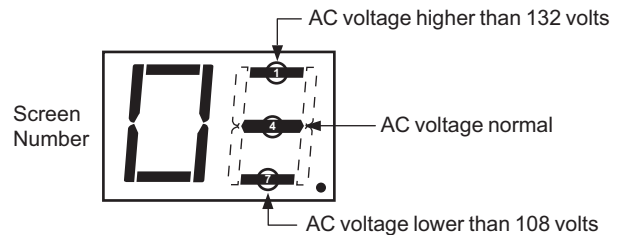

Press the  button to return to screen 1.

WIRING PICTORIALS & DIAGRAMS - SN 832170 & LOWER

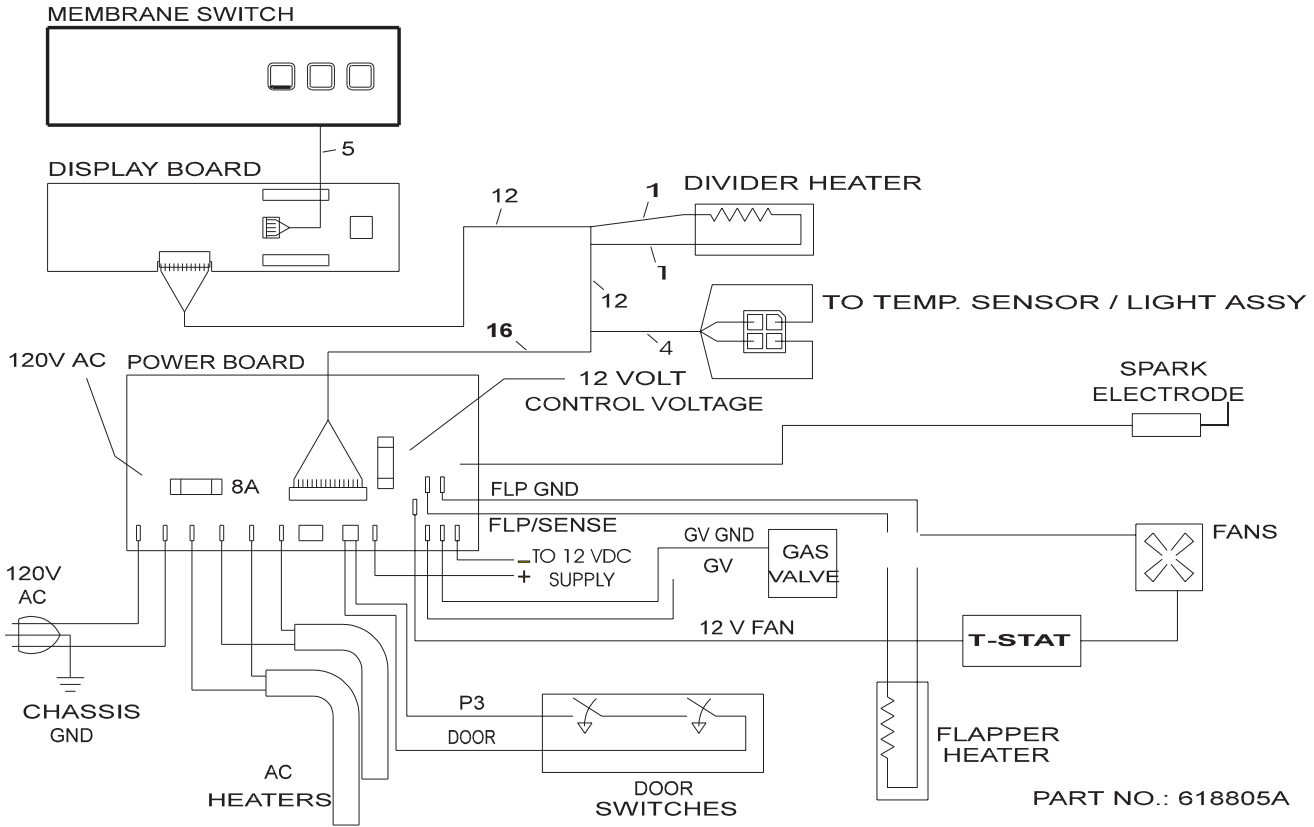

Figure 47. 1200XX/120X-IMXX pictorial - SN 832170 and lower

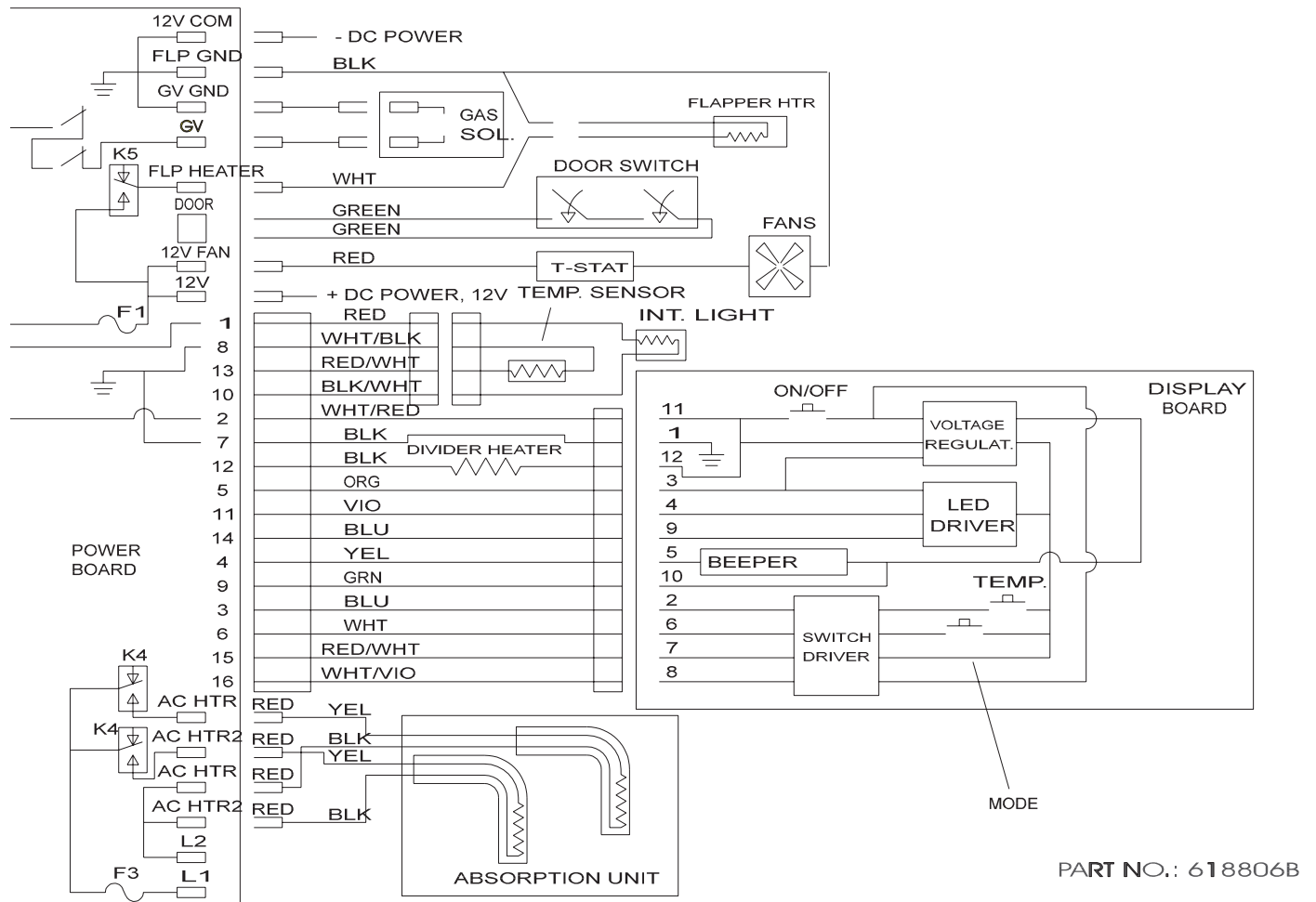
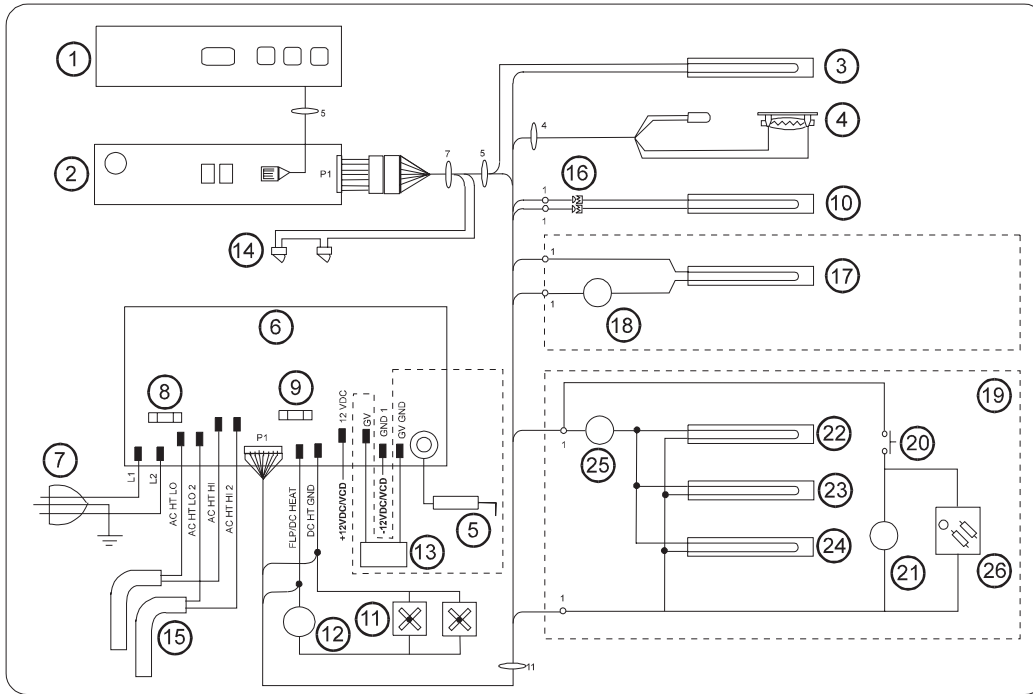

Figure 48. 1200XX/120X-IMXX wiring diagram - SN 832170 and lower

WIRING PICTORIALS & DIAGRAMS - SN 832171 & HIGHER



- | | | |
|-----------------------------|---------------------------------|---------------------------------|
| ① Display overlay | ⑩ Movable door seal heater | ⑲ Dispenser board* |
| ② Display board | ⑪ Fans | ⑳ Dispenser microswitch* |
| ③ Divider heater | ⑫ Temperature switch | ㉑ Dispenser valve* |
| ④ Thermistor/light assembly | ⑬ Gas valve*** | ㉒ Water valve heater* |
| ⑤ Ignitor*** | ⑭ Door switches | ㉓ Dispenser water line heater* |
| ⑥ Power board | ⑮ AC heaters | ㉔ Ice maker water line heater** |
| ⑦ 12 Vac power cord | ⑯ Door contacts | ㉕ Temperature switch* |
| ⑧ 5 amp fuse (120 Vac) | ⑰ Ice maker water line heater** | ㉖ Dispenser light* |
| ⑨ 5 amp fuse (12 Vdc) | ⑱ Temperature switch** | |

* Water dispenser models only

** Ice maker models only

*** Gas models only

Figure 49. 1200XX/120X-IMXX wiring pictorial - SN 832171 and higher

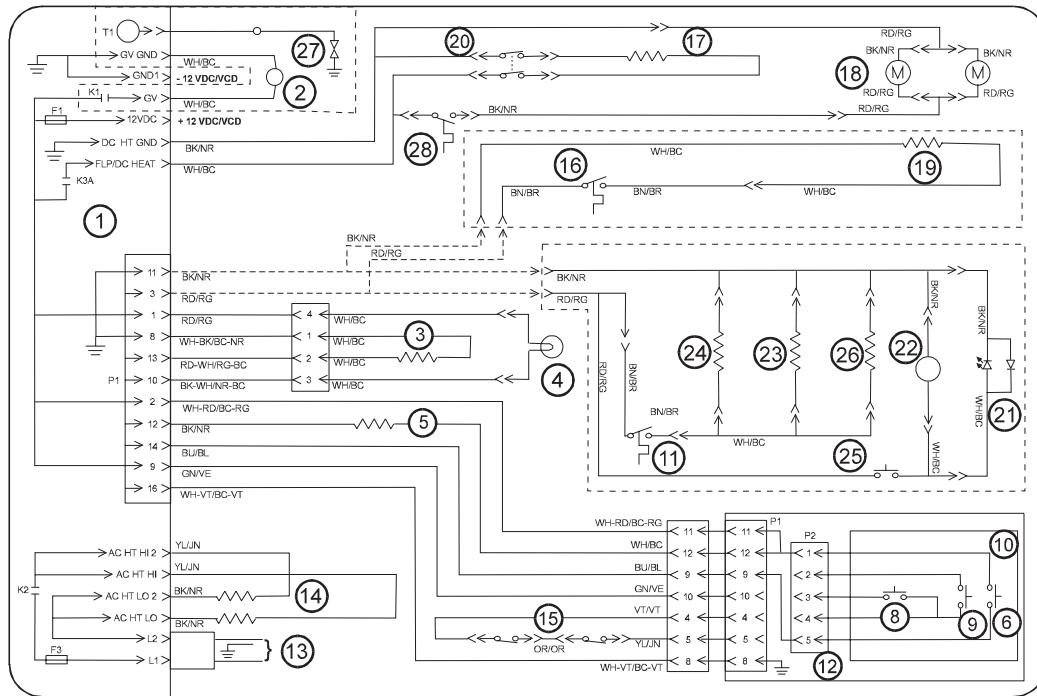

- | | | |
|----------------------|------------------------|---------------------------------|
| ① Power board | ⑪ Temperature switch* | ⑳ Dispenser light* |
| ② Gas valve*** | ⑫ Display board | ㉑ Dispenser valve* |
| ③ Temperature switch | ⑬ 120 Vac connection | ⑳ Water valve heater* |
| ④ Interior light | ⑭ AC heaters | ㉒ Dispenser water line heater* |
| ⑤ Divider heater | ⑮ Door switches | ㉓ Dispenser microswitch* |
| ⑥ ON/OFF switch | ⑯ Temperature switch** | ㉔ Ice maker water line heater** |
| ⑦ Voltage regulator | ⑰ Flapper heater | ㉕ Ignitor*** |
| ⑧ MODE button | ⑱ Fans | ㉖ Temperature switch |
| ⑨ TEMP SET button | ㉑ Water line heater** | |
| ⑩ Overlay | ㉒ Door contacts | |

* Water dispenser models only

** Ice maker models only

*** Gas models only

Figure 50. 1200XX/120X-IMXX wiring diagram - SN 832171 and higher

ICE MAKER COMPONENTS AND SERVICE

The ice maker is a factory installed accessory located on the right side of the freezer compartment. The components that support the ice maker are the wire harness, water fill tube, water fill line, and water valve. An ice maker cannot be added to a refrigerator that was manufactured without an ice maker.

Specifications

Cycle.....	One revolution (eject and water fill)
Water fill capacity	4.7 fl. oz. (140 mL)
Ice yield	3.5 lbs/24 hrs. (approximate)
Cycle duration.....	3.5 to 7 minutes
Electrical rating.....	185 W @115 volts AC/60 Hz
Amp draw	
Cycle on/heater on.....	1.6 A
Cycle on/heater off.....	0.3 A
Cycle off	No amp draw
Motor	1.5 W/8800 Ω
Mold heater.....	185 W/72 Ω

Wire Harness

The ice maker wire harness, see Figure 51, connects the ice maker to the 120 volt AC ice maker power cord. The assembly is bundled together with plastic ties. The wire harness runs through the surface of the cooling unit foam plug. On the upper ice maker end the harness has a modular plug with a locking tab (see Figure 51). Each wire on the harness has the appropriate connector to connect to the ice maker AC power cord (white AC cord). The four wires making up the wire harness are:

- **Black** - *Line voltage (L)* - black wire with female quick-connect terminal. This conductor is equipped with a thermal fuse. The thermal fuse is held onto the ice mold by a spring clip.
- **White** - *Neutral (N)* - white wire with male quick-connect terminal. It connects to the AC power cord neutral wire.
- **Brown** - *Water valve line voltage* - brown wire with female quick-connect terminal. It connects to the water valve solenoid, terminal M.
- **Green** - *Ground wire* - green wire with lug terminal. It connects to the refrigerator cabinet metal plate.

The refrigerator has to be removed from the enclosure to replace the ice maker wire harness.

NOTE

The ice maker wire harness is not the same as nor connected to the wire harness that serves the power board and the optical display assembly, as described on pages 39 and 40.

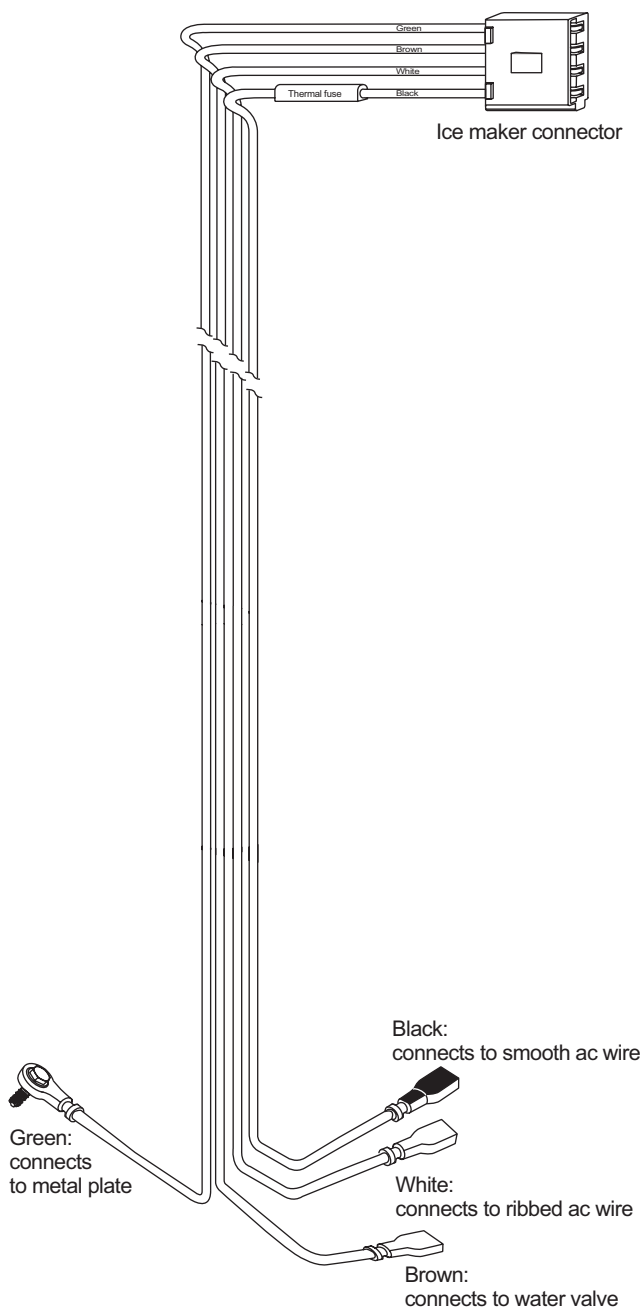

Figure 51. Ice maker wire harness

Water Fill Tube

The water fill tube connects the water fill line to the ice maker. It penetrates into the freezer cabinet from the rear of the refrigerator. This tube is factory installed and sealed and should not be disturbed or removed; it cannot be replaced. See Figure 57 for the location of the water fill tube.

Water Fill Line

The water fill line connects the water fill tube to the water valve at the bottom of the refrigerator. It is constructed of 1/4 inch plastic tubing. It connects to the water valve and water fill tube with 1/4 inch compression style fittings. See Figure 52. The water line is encased in a 12 volt DC foil style strip heater. To replace the water fill line the refrigerator must be removed from the enclosure.

12 volt DC Water Line Heater

The water line heater encases the entire length of the water fill line. This heater requires 12 volt DC power input for operation.

Heater on/off operation is automatically controlled by a circular thermostatic switch. See Figure 52. The switch is "clipped" to the water valve bracket. It turns on the heater when the surrounding temperature is 38° F, ±4° (34° to 42° F). It turns off the heater when the ambient temperature is approximately 48°F.

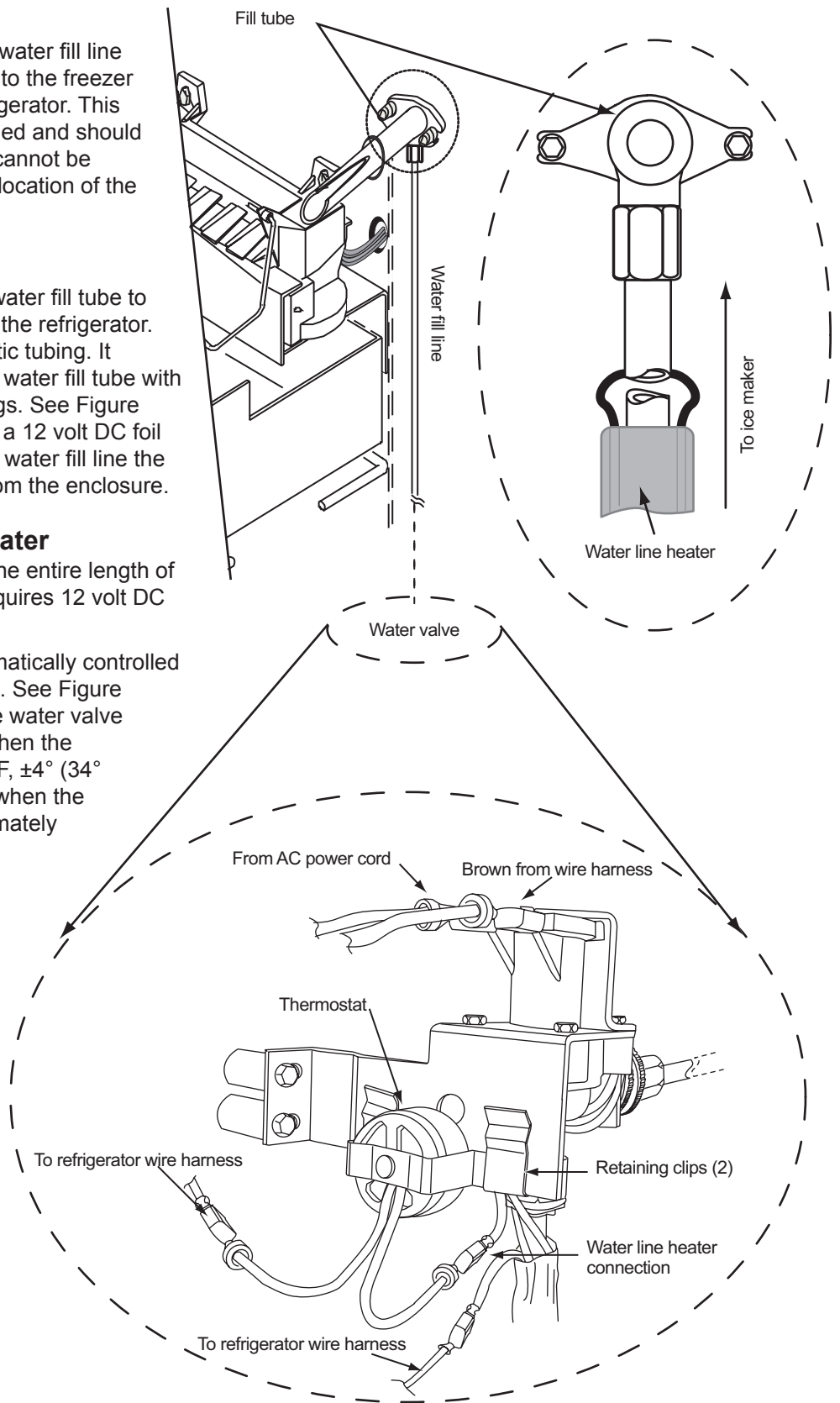

Figure 52. Water fill tube, line, and heater

Water Valve (Without Water Dispenser)

The water valve, see Figure 53, opens when the solenoid coil is energized. This valve is located on the back of the cabinet on the bottom of the refrigerator. The solenoid is supplied 120 volt AC through the ice maker wire harness. Spring pressure shuts maintains the valve shut when the solenoid coil is de-energized.

Water Valve Replacement Procedure

1. Turn the refrigerator OFF.
2. Unplug both the ice maker AC power cord and the refrigerator AC power cord from the RV receptacle.
3. Shut off the water supply to the ice maker.
4. Disconnect the wires from the water valve solenoid terminals.
5. Disconnect the white heater wire from the thermostat wire (white-from-brown).
6. Disconnect remaining white heater wire from wire harness lead (white-from-red).
7. Disconnect the brown thermostat wire from wire harness (brown-from-red).
8. Disconnect the water supply line from valve's inlet fitting.
9. Disconnect the ice maker water line.
10. Remove the thermostat clips (2) and thermostat. Retain thermostat and clips.
11. Unwrap the heater wire from water valve.
12. Remove the water valve retaining screws, then remove the water valve/bracket assembly. Retain screws and spacers.

To install replacement solenoid water valve:

1. Install the replacement water valve/bracket assembly on the refrigerator. Use screws and spacers previously removed.
2. Clip the thermostat to water valve bracket. Use clips previously removed.
3. Carefully wrap one white heater wire around the valve as shown in Figure 54. *Do not exceed two wraps at each point.*
4. Tape wire wraps to keep the wire turns in position and to keep wire turns from overlapping. *Do not allow wires to overlap.*
5. Connect the wrapped white heater wire to a thermostat wire (brown).
6. Connect the remaining white heater wire to the black wire connected to the refrigerator wire harness
7. Connect the remaining thermostat brown wire to the red wire connected to the refrigerator wire harness.
8. Connect ice maker water line, then tighten fitting firmly. *Do not overtighten.*
9. Connect RV water supply to water valve, then tighten fitting firmly. *Do not overtighten.*
10. Connect solenoid wires. *Brown wire to terminal M and wire from 120 volt AC power cord to terminal B4.*
11. Open water supply to ice maker.
12. Plug in both ice maker AC power cord and the refrigerator AC power cord.
13. Place refrigerator in service.

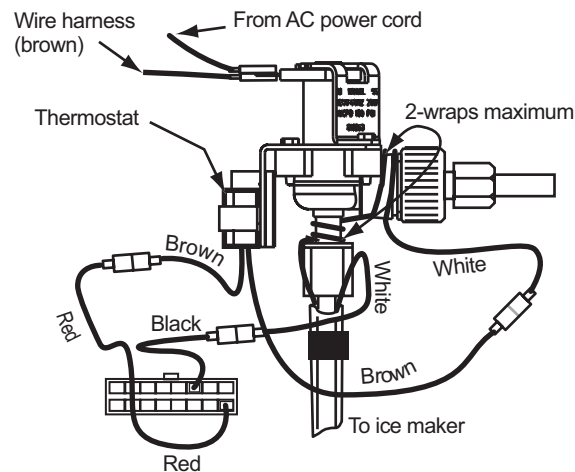

Figure 53. Solenoid water valve

Ice Maker Troubleshooting Chart

Problem	Probable Causes	Remedy
No ice in mold/ no ice yield.	A. No AC power to ice maker. B. No water available to water valve. C. Clogged water valve strainer. D. Water valve solenoid faulty.	A. Check AC power supply. B. Check water supply to valve. C. Clean water valve strainer. D. Test water valve. See page 59.
Not cycling, ice in mold.	A. No AC power to ice maker. B. Ice maker OFF. C. Mold overfilled. D. Water valve washer seal damaged.	A. Check AC power supply. B. Lower shutoff arm to ON position. C. Check position of water valve orifice. Reposition components. D. Replace water valve.
Water dripping from mold/mold overflowing.	A. Water fill adjustment screw set incorrectly. B. Water valve washer seal damaged.	A. Readjust water adjustment screw. See page 62. B. Replace water valve. See page 56.
Not cycling, AC power available.	A. Mold heater failed open. B. Motor faulty. C. Mold thermostat faulty. D. Wire harness thermal fuse open.	A. Check motor continuity. See page 63. B. Check motor continuity. See page 63. C. Replace ice maker. See page 60. D. Check continuity of black wire harness wire.

Water Valve Service (Models without Water Dispenser)

The water valve inlet strainer should be checked annually for scale and sediment deposits. The inlet connection internal components should only be checked when the mold overfills. To access the strainer and the components housed in the inlet fitting (see Figure 54):

1. Shut off the water supply to the ice maker.
2. Disconnect the inlet fitting adapter from the water valve inlet.
3. Check strainer position. If the strainer is seated approximately 1/8 inch in the fitting, the orifice seat, orifice, diffuser plate and strainer are in their correct position. A creased strainer end usually indicates that the diffuser plate, orifice, and orifice seat are not in their correct position. These components should be repositioned as shown in Figure 54. To reposition components correctly:
 - a. Press the orifice seat fully against the valve support, then seat the orifice firmly into the orifice seat.
 - b. Seat the diffuser plate firmly against the orifice.
 - c. Seat the strainer firmly against the orifice plate.
 - d. Reconnect the inlet fitting adapter to the water valve.

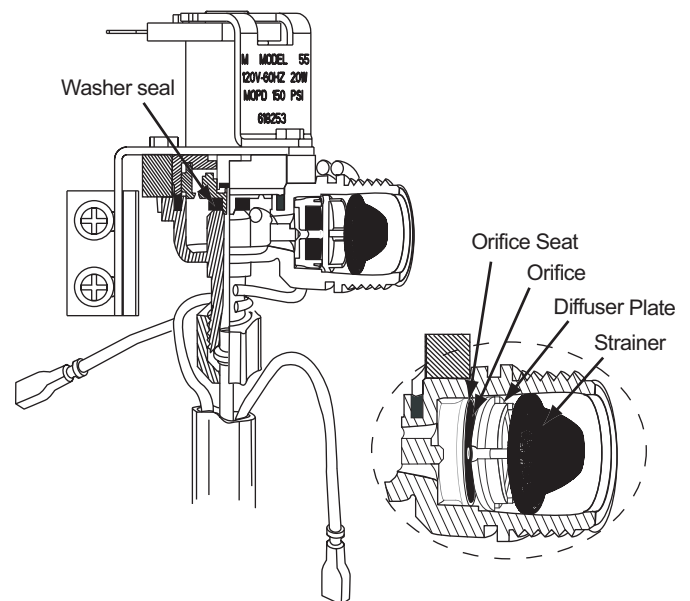

Figure 54. Solenoid water valve components

Replacing Ice Maker

Removal of existing ice maker:

NOTE

Be sure to save all screws and other components removed from the existing ice maker in this procedure, as these screws and components will be used when installing the replacement ice maker.

1. Turn refrigerator OFF.
2. Unplug both the ice maker AC power cord (white) and the refrigerator AC power cord (black).
3. Remove the ice bin, then remove the freezer shelf.
4. Unfasten two retaining screws to detach the ice maker from mounting plate. See Figure 55. Save screws.
5. Unfasten two freezer plate screws to detach mounting plate from the freezer. Save screws and flat washers.
6. Unfasten the upper bracket screws. Save screws.
7. Rotate ice maker until the front of the cover faces the door opening, then remove the cover.
8. Unclip the thermal fuse from the mold. See Figure 56.
9. Unplug the wire harness connector. See Figure 56.
10. Remove shutoff arm. Save shutoff arm.

Installation of replacement ice maker:

1. Install the shutoff arm onto the replacement ice maker.
2. Plug the wire harness connector into the ice maker. *Make sure connector locks into ice maker connector.*
3. Clip the thermal fuse to the mold.
4. Install the cover, then rotate ice maker parallel with the freezer plate, then align the upper bracket with screw holes.
5. Install and fasten the upper bracket screws. *Do not overtighten screws.*
6. Install the mounting plate.
7. Fasten the mounting plate to the ice maker with two retaining screws. *Do not overtighten retaining screws.*
8. Install retaining screws to fasten the ice maker to the mounting plate. *Do not overtighten screws.*
9. Install the freezer shelf, then install the ice bin.
10. Plug both the ice maker and the refrigerator AC power cords into the RV receptacle. See NOTE.
11. Turn refrigerator ON.

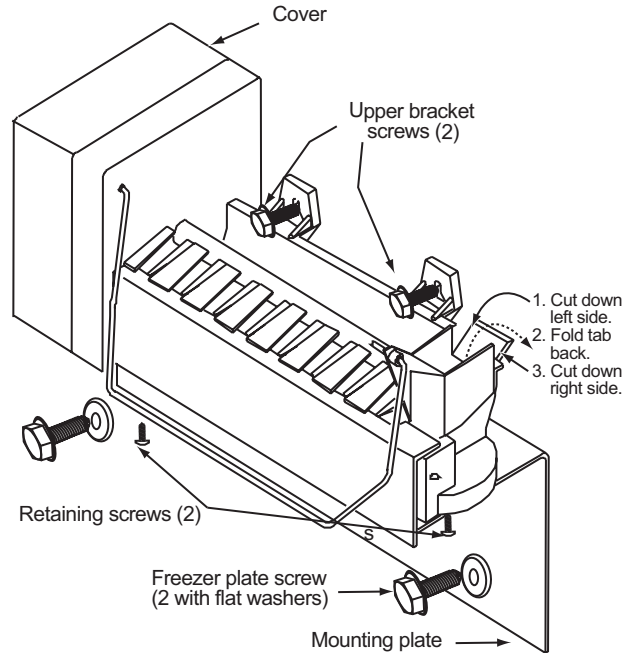
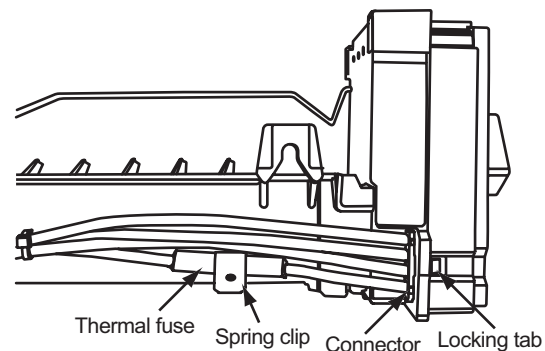

Figure 55. Ice maker screw locations

NOTE

The white AC power cord is plugged into AC outlet labeled "Ice Maker." The black AC power cord is plugged into the outlet labeled "Refrigerator" or "Inverter" (I).



To disconnect the wire harness from ice maker:

1. Unclip thermal fuse.
2. Push connector in.
3. Press in locking tab with small flat blade screwdriver. While pressing locking tab, pull back on wire harness to unplug the connector from ice maker.

Figure 56. Wire harness connection to ice maker

Cycle Testing Ice Maker

Cycle testing the ice maker verifies if the ice maker completes all cycle functions. *The cycle test is to be done with the ice maker dry.* To cycle the ice maker operation manually:

1. Shut off the water supply to the ice maker water valve.
2. Make sure 120volt AC is available to the ice maker.
3. Remove ice maker cover.
4. Make sure shutoff arm is fully down position (on).



Remove jumper wire immediately after “click” sound or no later than 15 seconds after jumping terminals T and H. Failure to remove jumper wire may damage the ice maker.

5. Jump terminals T and H. Use a 14 AWG jumper wire with 1/2 inch insulation stripped from each end. Jumper wire is shown in Figure 57. The jumping of T and H is shown in Figure 58.
6. The ejector should begin to rotate clockwise starting at the 2 o'clock stop position.
7. Remove jumper wire from terminals T and H when a “click” sound is heard and no later than 15 seconds after jumping the terminals.
8. Observe ice maker operation as ejector rotates.
9. After the ice cubes break loose from the mold, the ice maker should cycle without stopping. If the ice maker stops, or makes loud noises, replace ice maker. See section "Replacing Ice Maker," page 60.

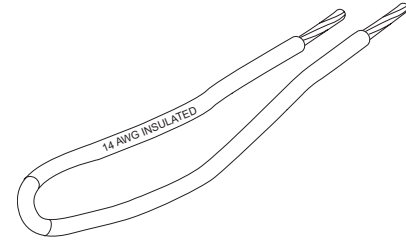

Figure 57. Jumper wire

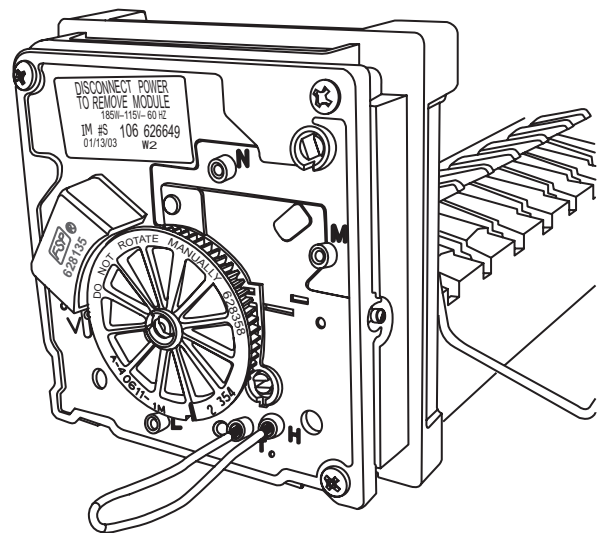

Figure 58. Cycle testing ice maker

Checking Water Valve Operation

To check water valve operation:

1. Remove the ice maker cover.
2. Jump test point V and L. See Figure 64. Use a 14 AWG jumper wire with 1/2 inch insulation stripped from each end (as shown in Figure 57). The solenoid should click and buzz if it is operating properly. If the solenoid does not click and buzz, replace the water valve (see page 58).

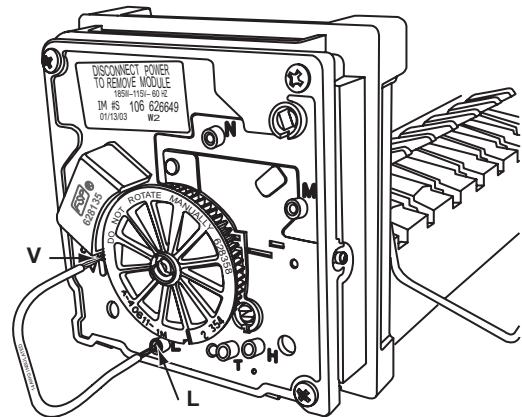

Figure 59. Checking water valve operation

Water Fill Adjustment

The water fill adjustment screw is set at the factory. In most cases, the production of thin ice cubes or the ice maker not cycling correctly is related to an unauthorized field adjustment to the water fill adjustment screw. Proceed as follows to adjust the water fill adjustment screw.

1. Remove the two screws holding the ice maker to the mounting plate. See Figure 55, page 60.
2. Remove the mounting plate from the freezer plate.
3. Remove two screws from the ice maker upper mounting brackets.
4. Position the ice maker with the cover facing out. *Do not pull on wire harness.*
5. Locate the screw and contact alignment opening shown in Figure 60.
6. Determine the position of the hole in the internal contact plate. *Do not adjust the water fill adjustment screw if the hole is centered within the housing hole.* See Figure 64.

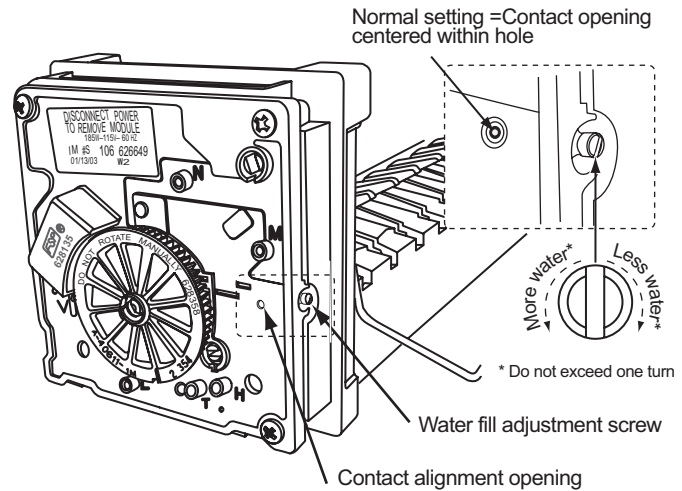

Figure 60. Water fill adjustment screw



CAUTION

Do not turn the water fill adjustment screw over one turn. Turning the screw over one turn may damage the contacts. A 1/4 turn, clockwise or counterclockwise, will vary the fill by 0.34fl.oz. (10 mL).

7. To readjust the water fill level turn the adjustment screw clockwise or counterclockwise as required until the contact hole is centered in the module hole. See Figure 60.

Checking Water Valve Solenoid Resistance

To check water valve solenoid resistance:

1. Disconnect AC power to the ice maker.
 2. Remove the ice maker cover.
 3. Set multimeter to Ohm scale, then connect probes to test points V and N. See Figure 61. The test probe tips must be 1/2 inch long to make full contact with internal terminals.
- 295 to 360 Ω —water valve solenoid operating properly.
 - OL—check for loose wire harness connections at water valve or an open solenoid coil.
 - 00.0 Ω —check resistance at solenoid terminals and wire harness continuity.

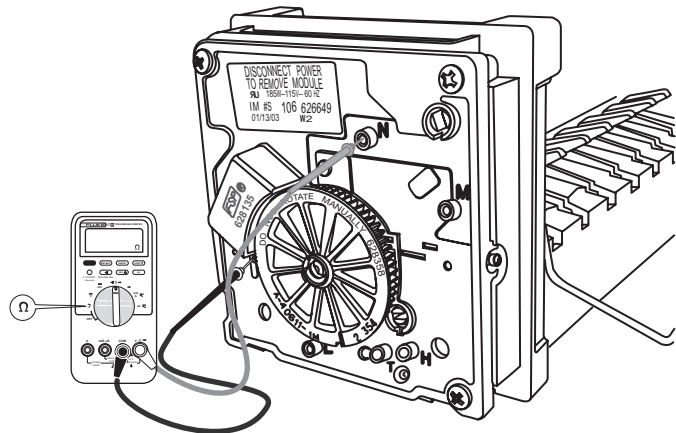

Figure 61. Checking solenoid resistance

Checking Mold Heater Resistance

To check the mold heater resistance:

1. Unplug the ice maker AC power cord.
 2. Remove ice maker cover.
 3. Set multimeter to Ohm scale, then connect probes to test points L and H. Test probe tips must be 1/2 inch long to make full contact with internal terminals. See Figure 62.
- 71 to 79 Ω —mold heater is operating properly.
 - Below 71 Ω or above 79 Ω —replace ice maker.
 - OL—open heater, replace ice maker.

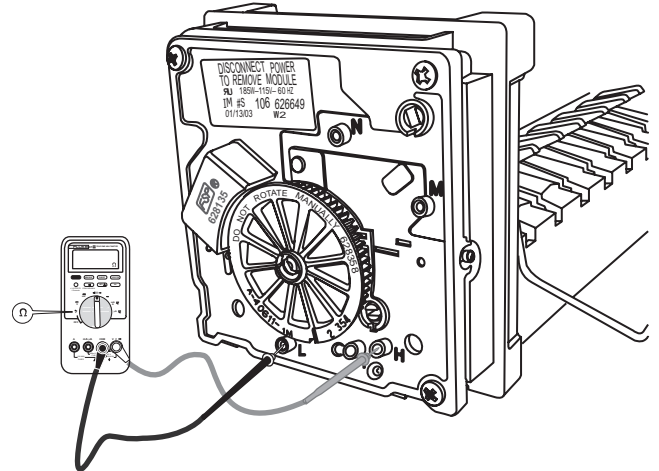

Figure 62. Checking mold heater resistance

Checking Voltage to Motor

To check voltage supply to motor:

1. Make sure 120 volt AC is available to the ice maker.
 2. Remove ice maker cover.
 3. Set multimeter to AC scale, then connect probes to test point N and M. See Figure 63. Test probe tips must be 1/2 inch long to make full contact with internal terminals. Voltage at the motor should measure 108 to 132 volts.
- Voltage higher than 132 volts—check incoming ac power source and correct overvoltage condition.
 - Voltage lower than 108 volts—check incoming AC power source and correct under-voltage condition.
 - No voltage present—check wire connections and continuity through thermal fuse.

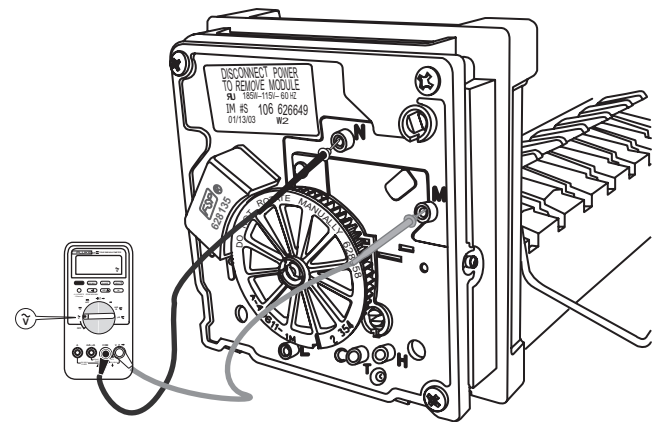

Figure 63. Checking voltage to motor

Winterization

To winterize the water valve and water line:

1. Shut off RV water supply to the ice maker.
2. Raise and lock shutoff arm in OFF position.
3. Disconnect the water inlet adapter from water valve.
4. Disconnect the ice maker water line from water valve..

NOTE

The water line heater wire must be re-wrapped properly around the water valve body when the water line is reconnected to the water valve. See Figure 53, page 58.

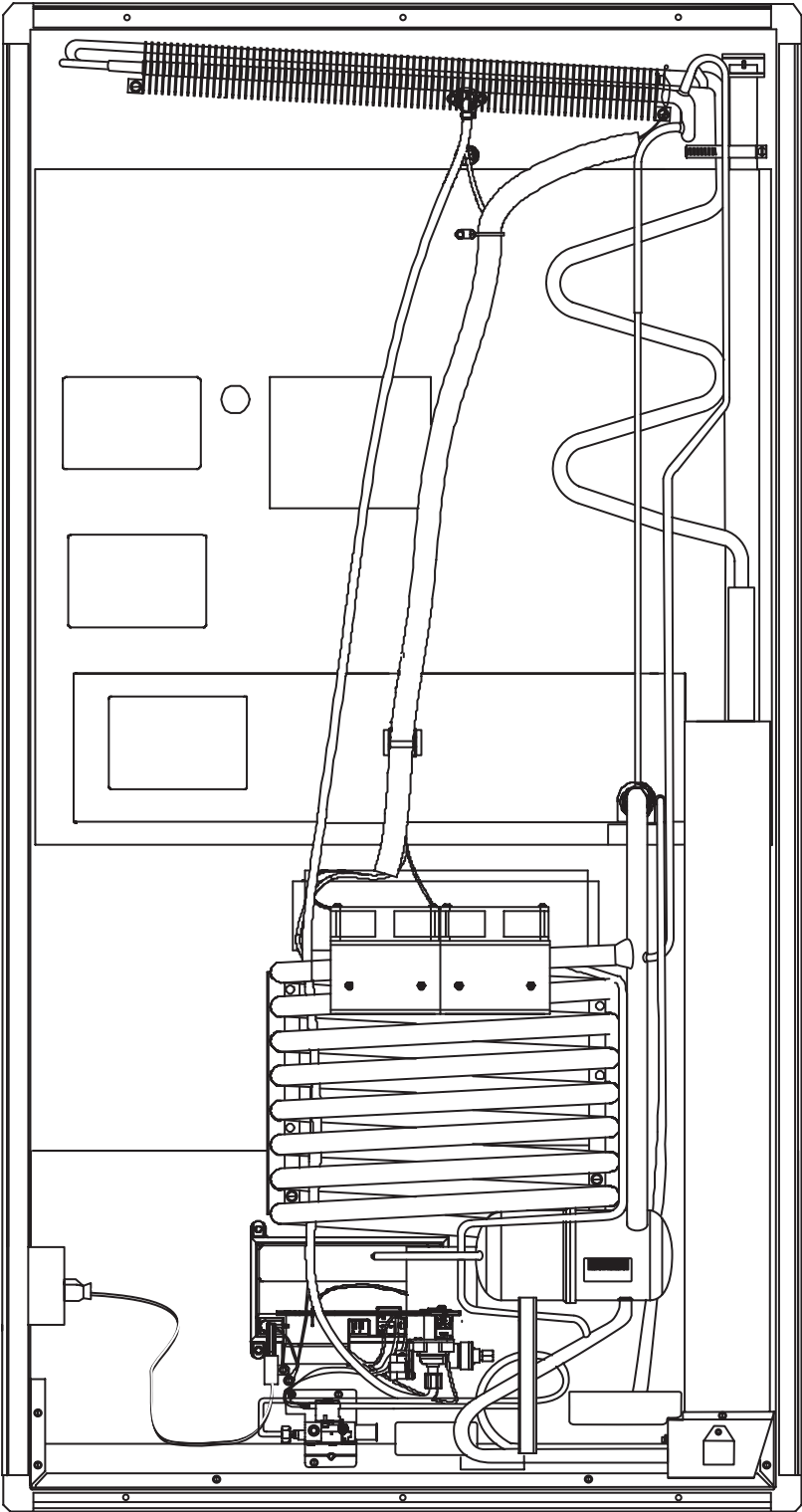

NORCOLD, INC.
P. O. Box 4248
Sidney, OH 45365-4248

NORCOLD CUSTOMER SERVICE
Telephone 1-800-444-7210
Fax 937-497-3183
World Wide Web www.norcold.com/cda